

Product Manual

Display Express

Display Express PC

Display Express Software

Version 5.6.0, DX Update Version 5.6.1
March 20, 2012

Table of Contents

Display Express Software Installation	4
What's new in version 5.6.0/5.6.1	4
Introduction	4
Display Express Service	4
Internet Information Services	4
Web Access to Display Express	4
Windows Firewall Exceptions for Display Express	5
Setup Tips for all Display Express Applications	6
Controller Installation	6
PC Setup	6
Software Updates	6
Display Express PC Setup	6
Subnet Mask: 255.255.255.0	6
Gateway Address: 000.000.000.000	6
Telnet TCP Port: 2728 Telnet Access	6
Head End Installation	7
RS-232 Control	7
Ethernet Control	8
Reset IP Address	8
RF Setup	8
Display Zones	9
DX Find	10
Display Express	11
Versions	11
Local Access (Within LAN)	12
Login	12
Setup – Options	13
Head End Communication	13
Tuning System	13
Logging	13
Description	13
System Information	13
Setup - Users	14
Setup – Name Displays and Zones	15
Changing Zone Names	15
Display Names	15
Setup – Groups	16
Setup – Name Channels	17
Web Panels - Control, List, and TV Control Panels	18
Control Panels – Control Panel Editing	19
Control Panels - TV Panel Editing	20
Control Panels – Assigning Users to Panels	21
Presets – Macros	22
Presets– Edit	23
Editing Modes	23
Macros or Commands	24
Presets – Advanced Presets	26
Creating a “Matrix” Preset	26
Presets – System	28
External Presets	29

Schedule - Control	30
Schedule - Edit	31
Schedule Modes	31
Schedule Preset.....	31
Alerts - Control	32
Alerts - Edit	33
Editing Modes	33
Alert	33
Telnet Commands.....	34
Display Express TCP	34
SSCmd.....	34

Display Express Software Installation

What's new in version 5.6.0/5.6.1

TV Control Panels. Designed for sports bars and other applications that want the ability to mix manual TV control with Presets and Scheduling features.

The first version number applies to new DX installs; the second is the update version for existing DX systems. Updates for all existing DX systems can be found at www.crwww.com/downloads.asp.

Introduction

Display Express is now available in two forms, an installation CD for Windows XP Pro. Windows 7 Pro PCs and Server 2003 servers, and preinstalled in a rack-mount PC. This manual covers both applications in three sections:

- Software Installation
- PC and System Setup
- Software Operation

Display Express Service

Display Express Service (manages data handling on Web pages) must be run on Windows XP Pro or 7 Pro 32- and 64- bit. After installation, the Display Express Service will be started automatically, and every time the computer is booted it will be started automatically. If you want to start the service manually instead, you can do this by going to Start Menu > Control Panel > Administrative Tools > Services. Scroll down to Display Express. By right-clicking, you can change the start option to manual.

You can also start and stop the service using the Services Dialog.

Internet Information Services

Internet Information Services (IIS) should be installed on your computer before Display Express is installed. To find out if IIS is installed on Windows XP, click on Control Panel > Add or Remove Programs, then click on the Add/Remove Windows Components icon on the left. In the next window, scroll down and find Internet Information Services. If it does not have a check mark next to it, then it is not installed.

To install IIS, click to put a check mark next to IIS, then click on Next, etc. You will need the CD used to install your operating system if the files are not installed on your hard drive, or the installation files may be stored in the server. On Windows Server 2003, look for Application Server instead of Internet Information Services in the Add/Remove Windows Components dialog. The PC will likely need to restart.

On Windows 7, go to Control Panel > Programs and Features > Turn Windows Features On or Off > Internet Information Services (IIS), and check the box. Then, click on the + next to IIS, click on the + at World Wide Web Services, + at Application Development Features, then click the box for ASP.NET.

Web Access to Display Express

When you install Display Express, the installer gives you a choice of standalone, LAN or WAN configuration. In Standalone mode, no UDP/TCP ports are created, so only the user at the PC can access Display Express. In LAN mode, the ports are opened for local LAN access only, and WAN setting opens access to browsers outside your local LAN. Additional IT services are required to enable remote WAN access. To change access, manually uninstall the software from Control Panel, then re-install. No data will be lost.

Windows Firewall Exceptions for Display Express

If LAN or WAN configuration is selected during installation, three firewall exceptions will be created: Display Express TCP, TCP port 2728, (local area network or any computer) Display Express UDP, UDP port 2728, (local area network or any computer) http://localhost/DX, TCP port 80, (local area or any computer).

Server Operation

Presently, Display Express has been tested for installation on Server 2003, Windows XP and Windows 7 Pro, 32- and 64-bit.

Sites that use Display Express on a Server should use the ICE-HE Ethernet Head End. This unit can communicate to the server via Ethernet using Telnet, and then inserts the control commands over RF as a micro-channel between channels 4 and 5.

Setup Tips for all Display Express Applications

Your installation will go well if you keep a few key facts in mind. If you don't understand a bullet point, read the rest of the manual or call CR Support.

Controller Installation

- **Create a spreadsheet and divide the system into Zones before you begin.** Otherwise, you'll need to change the controller addresses later on.
- **Pre-test display control on at least one controller and display before starting.** You can use a Head End and iC Send to test on and off control. In most cases, all displays and controller settings are the same across the system. If some are different, pre-test those, if possible.

PC Setup

- **Change the Time Zone when you install the PC.** All the units are shipped sent to Central or Pacific Time. Also enable to synchronize with an Internet time server if possible (some networks may block that). Remote PCs will display the Display Express web server's time and date on the browser.

Software Updates

- New versions of Display Express can be installed over previous versions. You won't lose any data or settings.
- Updaters for existing Display Express software are available on the CR website, www.crwww.com/downloads.

Display Express PC Setup

General

- Windows 7 Pro 32-Bit software installed
- Web operation provided by Localhost IIS service
- Operating system and program files in C: drive

Ethernet

IP Address: 192.168.1.245
Subnet Mask: 255.255.255.0
Gateway Address: 000.000.000.000

Telnet TCP Port: 2728 Telnet Access
UDP Port: 2729 For remote Find access
80 For Web Access

Web Access: Internal Access - <http://localhost/DX/>
External Access - <http://<IP address>/DX/>
External Access - <http://<Computer Name>/DX/>

Head End Installation

In most applications, the Display Express PC will be installed adjacent to a Contemporary Research ICC-HE Head End or ICE-HE Ethernet Head End. Both can receive commands via RS-232 and insert the commands into the RF system as a small control channel between TV channels 4 and 5. Instructions for connecting the DX PC to the ICE-HE Ethernet Head End over IP are included on the next page. Additional instructions are included in the ICE-HE Head End manual.

RS-232 Control

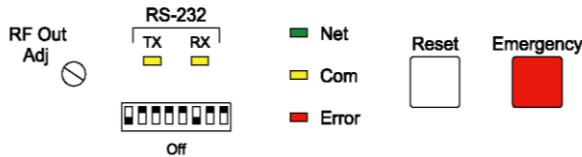

Check the front panel of the Head End, as shown above, and see if the last 3 DIP switches under the RS-232 LED are set as follows:

- Switch 6 Off (Down)
- Switch 7 On (Up)
- Switch 8 On (Up)

This sets the speed of communication to 19,200 baud.

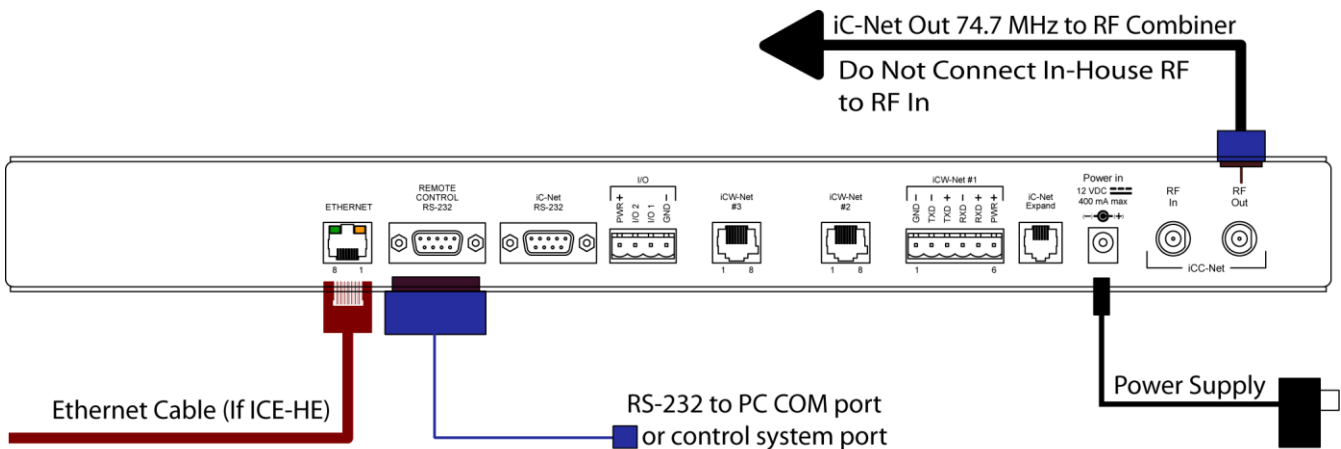

Next, connect the included RS-232 cable between the PC's 9-pin RS-232 port or USB adapter to the RS-232 Remote Control port on the back of the ICC-HE. The ICE-HE can also receive control commands via IP.

Tech Note. Do not use the RF IN on the HE to pass through the entire RF feed through the HE. It's not a combiner input and doesn't pass any RF. Connect the RF OUT to a combiner input with the rest of the cable and modulator feeds.

Ethernet Control

The ICE-HE typically communicates over a network using a static IP address, and is shipped set to a default address:

IP Address: 192.168.1.251
Subnet Mask: 255.255.255.0
Gateway Address: 000.000.000.000

Odds are, at least the IP address will change when the ICE-HE is connected to the client's network. One your first steps will be to obtain a static address from the client's IT department, as well as an external gateway IP address if you intend on supporting the system from your office or anywhere outside the site's firewall.

Once you change the settings, create a label noting the settings and attach to the back of the ICE-HE.

Reset IP Address

If you change the default address and forget what it is later on, you can always reset the ICE-HE back to the default settings using the unit's front-panel DIP switch 2. While the power is on, flip the switch off, then back on to reset the IP address. The IP and Subnet Mask will change, the Gateway will stay at its current setting.

Since its possible another network device is using the default IP address, the best approach is to enter the new settings offline, outside the network. You can use one of two, requiring one of two offline options:

1. Direct PC Connection. Use an Ethernet "Crossover" cable to make a direct connection to the ICE-HE Ethernet port and your PC. Two pairs of wires are reversed at one end to create a direct send/receive path for data.
2. Hub or Switch Connection. Another approach for connection is to use a standard Ethernet hub or switch between your computer and the ICE-HE. Using standard Cat5 Ethernet cables, connect your PC to one port, then connect the ICE-HE to the second port.

RF Setup

The Head End sends the control channel at a level of 50 dBmV. In virtually all installations, the system installer has installed filters to the RF Out connection to match the level to the other RF channels. The manual that was shipped with the Head End provides more detail, if needed, can be downloaded from the Head End page in the www.crwww.com Web site.

Display Zones

Display Express assigns control to three entities:

- All Zones – All displays respond to a single command
- Zones – All displays within one of 15 Zones respond to a single command
- Single Display – Sends command to one display address

When you design your Display Express system, arrange your display addresses into one of the 15 zones. This allows you to control a group of displays as if they were one display.

Note that you can change the default names for Zones in Display Express – see Display – Setup in the Display Express section.

You'll discover that the ICC1-IR and ICC1-232 controllers typical for many Display Express RF control systems are designed to follow this Zone address format. You can use the 4 top switches in the second DIP switch to define the controller's Zone. You could stop at that point, or use the upper switches to define the controller's address within the Zone. For example, setting S2/1 On and S1/2 On defines that the controller is part of Zone 1 (256), and is the second unit in the Zone (2). The unique address of the controller would be 258 (256 + 2). The ICC2-ATSC follows a similar procedure – using front-panel programming, you set the unique Unit address (1-255), then the Zone (1-15).

Use the chart below as a guide to setting your Zones and addresses.

Zone	Device #	Unit	Total Device #
1	256	1-255	257-511
2	512	1-255	512-767
3	768	1-255	769-1023
4	1024	1-255	1025-1279
5	1280	1-255	1281-1535
6	1536	1-255	1537-1791
7	1792	1-255	1793-2047
8	2048	1-255	2049-2303
9	2304	1-255	2305-2559
10	2560	1-255	2561-2815
11	2816	1-255	2817-3071
12	3072	1-255	3073-3327
13	3328	1-255	3329-3583
14	3584	1-255	3585-3839
15	3840	1-255	3841-4094
All Zones	4095		

DX Find

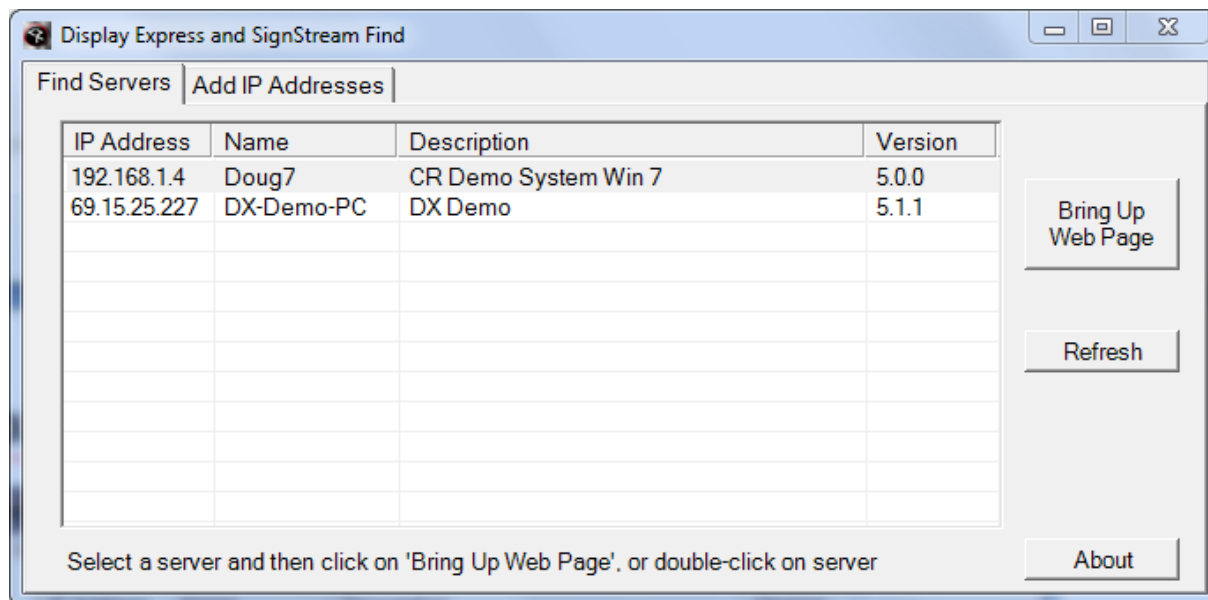

Contemporary Research offers an app to find Display Express servers, called DX Find. This application can be downloaded from Download or Home pages at www.crwww.com. When launched, DX Find will find all the Display Express Web servers in your network.

Simply double-click on the desired server row (or click the Bring Up Web Page button) to display the Web pages from that server. You can also find Display Express applications outside your network with the Add IP Addresses tab. To allow external access the IT department needs provide access:

- Make sure the Server's Windows Firewall exceptions allows access to TCP 2728, UDP 2728 and TCP 80, set Change Scope to Any Computer, or My Network if you want to limit access to within your network.
- The network firewall needs to be set up for remote access to the server and UDP ports.

Display Express

DX Display Express Home Presets Schedules Alerts Setup

Home Schedule

Today's Schedule CR Demo Enabled Disabled

Preset	Time	Start	End	Days	Device	Power	HDTV	NTSC	Vol
All On	9:00 AM	10/25/2010		MTWRF	All Zones	On			
Left to Apps	9:01 AM	10/25/2010		MTWRF	Left Displays			Apps	
Center to Videos	9:01 AM	10/25/2010		MTWRF	Center Displays		Videos		
Right to Signage	9:01 AM	10/25/2010		MTWRF	Right Displays		Signage		
Right to Videos	11:00 AM	10/25/2010		MTWRF	Right Displays		Videos		
Left to Signage	11:00 AM	10/25/2010		MTWRF	Left Displays		Signage		
Center to Signage	11:00 AM	10/25/2010		MTWRF	Center Displays		Signage		
Left to Videos	1:00 PM	10/25/2010		MTWRF	Left Displays		Videos		
Right to Signage	1:00 PM	10/25/2010		MTWRF	Right Displays		Signage		
All Off	6:00 PM	10/25/2010		MTWRF	All Zones	Off			

< >

8/12/2011
10:35 AM

Contemporary Research

Home Page

Display Express manages displays via Web pages accessed from the local Display Express PC, any computer on the network, or remotely from a distant location. The pages are compatible with IE7-9, FireFox, Chrome, Opera, and Safari browsers.

Tip: Don't use the back or forward buttons on the browser – that will leave the server, but you can usually refresh to get back, but you'll lose the data you entered if you haven't saved the info.

Versions

Version 5 adds the ability to create any number of control panels, from a single column to 4 columns of 25 rows allowing simple access from any Web-enabled device, from Smartphones, tablets, laptops, or desktop PCs. This version adds another class of user – the Panel User. When this person logs in, they can only access the Web control panels assigned to them. Alerts can now be combined with Presets on custom DX Panels.

Version 5.3.0 adds the ability to send custom commands to external devices over RS-232 or IP. Special iC-Net commands, such as changing IR code sets in IR controllers, can be included in Presets. Updates to Preset Control and improved database operation are also included.

Version 5.6.0 adds the ability to create TV Control Panels, where a user can select a Zone or Groups of TVs, or a specific TV, and select channels, inputs, volume level or power.

Local Access (Within LAN)

On the PC that has Display Express installed, Click on the Display Express icon on the desktop, or launch a browser and enter <http://localhost/DX/>.

From other computers on the LAN, you can:

- Install DX Find on the PC – it will locate Display Express for you (available at the bottom of CRwww.com home page.
- Point the browser to the Display Express URL on the network:
 - <http://<IP address>/DX/>
 - <http://<Computer Name>/DX/>

Remote Access (WAN)

For access outside the local LAN the PC hosting Display Express should normally be set as a static IP address. DX Find can locate Display Express by entering the static IP address for the Display Express server on the 'Add IP Addresses' tab. You'll need to communicate with your IT department to set up access to Display Express from outside the network.

Login



The image shows a web browser window displaying the Display Express login interface. At the top, there is a blue banner with the 'DX Display Express' logo. Below this is a yellow bar with the word 'Login' in black text. The main content area is a light gray box with a thin border. It contains two input fields: 'User Name' with the text 'Admin' entered, and 'Password' which is empty. Below the password field is a blue 'Login' button.

When you first access Display Express, you'll need to log in to the server. When first installed, the user name for access is "Admin" (no password) accesses full use and administrative rights to DX. Upper and lower case doesn't matter for the User Name, only the password.

Once you start setting up DX, you can create three types of users:

- **System Administrator** – access to all features and DX Panels
- **System User** – access to first panel in each section, all DX Panels, but no editing options
- **Panel User** – can only access DX Panels assigned to the user name

Log Off

You can log off DX by accessing the Home/Logoff menu, or close the browser.

Setup – Options

Head End Communication

RS232 Baud Rate: 19,200
COM Port: 3

IP Addresses e.g. 192.168.1.101
Specify up to 4 Head Ends.
192.168.0.40

Logging

Enable Logging Enable Debugging

Description

CR Demo System Win 7

Tuning System

 Cable Std
Air
Cable HRC
Cable IRC

Computer Name	Doug7
IP Address	192.168.1.9
Display Express Version	5.3.9

The **Setup Options** pages define how Display Express connects to the system Head End and basic channel tuning operation.

Head End Communication

Sets the form of communication to an ICC-HE or ICE-HE Head End. The ICC-HE communicates via RS-232, while the ICE-HE can handle data via Ethernet and RS-232. The RS-232 baud rate is normally set to 19,200. With Version 3.5, the user can specify up to four ICE-HE Ethernet Head Ends. Data will be set to all Head Ends at the same time, each Head End would be comprised of different Zones of displays.

Tuning System

Note, this is a legacy tool for older systems with Smart TVs. At most sites, the type of tuning is defined by the scanning process in the HDTV display.

Logging

Enable logging or debugging features. Only use if asked by Contemporary Research Support.

Description

Change the name of the Display Express app displayed when found by the DX Find app.

System Information

Lists the computer name, IP address and Display Express version.

Setup - Users

DX Display Express Home Presets Schedules Alerts Setup

Setup Users

Create New User
 Edit Existing User
 Copy Existing User

Admin
iPhone
Sys User
Tablet

User Save Delete

Name iPhone

Password Up to 16 uppercase, lowercase or numeric characters, e.g. Administrator234

Role
 System Administrator Edits and controls presets, schedules and alerts
 System User Controls presets, schedules and alerts
 Panel User Controls presets and alerts in assigned panels

Default Panel Left TVs

User's Panels Left TVs Right TVs

All Panels Default Panel Left TVs Right TVs

We've talked about this tool in the Panels section, primarily concerning setup of Panels Users. This page can also be used to create System Administrators and System users, similar to past versions of DX.

What's changed is that:

- Any user must log in to DX first
- You can create multiple System Administrators and Users
 - **System Administrator** – access to all features and DX Panels
 - **System User** – access to first panel in each section, all DX Panels, but no editing options
 - **Panel User** – can only access DX Panels assigned to the user name

When password access is enabled, the user must login when first accessing the pages. If desired, the password can be saved using the browser's "Remember Password" feature. Note that, if you save the password in User or Panel User mode, you may need to delete the password in the browser to enter admin mode (or use one browser for User access and another for Admin). Presently, Chrome 2.0 cannot remember the login password, but all other browsers are compatible with this feature. For added security, the password is encrypted when sent to the Display Express Web server.

Setup – Name Displays and Zones

DX Display Express Home Presets Schedules Alerts Setup

Setup Displays

Display Names

Sort by Name Sort by Display #

- 232-ATSC+ (258)
- ATSC TV (513)
- Center TV (769)
- LG TV (257)
- SBA 1 (1025)
- SBA 2 (1026)
- SBA 3 (1027)**
- SBA 4 (1028)
- SBA 5 (1029)
- SBA 6 (1030)
- SBA 7 (1031)
- SBB 1 (1101)
- SBB 2 (1102)
- SBB 3 (1103)
- SBB 4 (1104)
- SBB 5 (1105)

Name: SBA 3

Display #: 1027 1 - 4094

Save New Modify Delete

Zone Names

Zone: All Zones

New Name

Use Default All Zones

Change Name

In this section, you can create names for Zones and individual display controllers.

Changing Zone Names

The names of the Zones can be changed here. It's useful to start the text with the Zone number to remember which Zone the name represents. The list will always be sorted by the numeric order of the actual Zones.

Display Names

When you need to control specific displays, it's easier to find them by name. Using this tool, you can create a name for any specific address, and change or delete the name at any time.

Note that Display Express Presets won't be affected if you add, delete, or change a name.

Setup – Groups

DX Display Express Home Presets Schedules Alerts Setup

Setup Groups

Create New Group
 Edit Existing Group
 Copy Existing Group

Large Displays
SB 1
SB 2
SB 3
SB 4

Group Save Delete Click on a Group, Display, or Zone item to add.

Name Large Displays

Groups
SB 1
SB 2
SB 3
SB 4
SB 5
SB 6
SB 7
Small Displays

Displays
232-ATSC+ (258)
ATSC TV (513)
Center TV (769)
LG TV (257)
SBA 1 (1025)
SBA 2 (1026)
SBA 3 (1027)
SBA 4 (1028)
SBA 5 (1029)

Zones
All Zones
Right Displays
Left Displays
Center Displays
Sports Bars
Zone 5 (1281-1535)

Display #
+ 1 - 4094

The **Display Groups** enables creation of free-form Groups of displays. Unlike Zones, the list can include any individual or combination of controllers:

- Group – Select a Group, then click to add to the Group
- Zone - Select a Zone, then click to add to the Group
- Device - Select a named device, then click to add to the Group
- Device # - Enter a device number (address), then click + to add to the Group

Also unlike Zones, a Group preset will take longer to execute, because will need to Send the commands to devices sequentially (A Zone command sends a single address that all displays in the zone will respond to). The sequence will be in the order of entry.

Setup – Name Channels

Channel Labels

Sort by Label Sort by Channel

Apps (65)
Comcast 1 (25-1)
Comcast 2 (25-2)
DRTV 11 (26-1)
DRTV 2 (26-2)
Emergency (6-1)
ESPN 1 (20-1)
ESPN 2 (20-2)
ESPN 4 (20-3)
House (5-1)
Input HDMI1 (0-211)
Input TV (0-200)
Signage (120-1)
Ticket 1 (21-1)

Channel HDTV 20-3 e.g., 18-1 or 325
 NTSC 2 - 127

Label ESPN 4

Save New Modify Delete

Setup Channels

Resend All NTSC Labels To Head End

Clear All NTSC Labels In Head End

NTSC Tune Rings

Tune Ring 5-8 Tune

Name 5-8 Tune Clear

Channels 5-8

for example 2-13,24,36,55-58

Save New Modify Delete

DX can now create a list of TV channels, so you can now tune by name, rather than having to remember the number of the channel. Editing is simple. Just add the Label (Name) of the channel, select HDTV or NTSC, enter the number, and Save. You can go back and modify the channel – handy when the cable company changes channel locations.

Legacy Features

Where the system includes older Smart CRT TVs, you can send or clear the channel names in the TVs and well as set list of channels the sets are allowed to tune (called Tune Rings).

HDTV sets don't include the ability to name or control tuning. That is managed by the set's internal channel scanning.

TV Input/Captions Selection

It is possible to control input selection via Display Express as well. This is available for a limited list of IR controlled sets (LG, Panasonic, Visio, and ViewSonic) and RS-232 (LG) at this date, but we can add the capability to other IR and RS-232 sets when the need arises. Captioning does the typical IR toggling function, most sets don't have discrete caption on and off commands. Not all sets have every input.

You set up Inputs just like a channel, but define it as a zero HDTV channel (0-NNN). The Input codes are:

115=Captions	206=Component1	211=HDMI1
200=TV/Tuner	207=Component2	212=HDMI2
201=Video1	208=RGB1	213=HDMI3
202=Video2	209=RGB2	214=HDMI4
203=Video3	210=RGB3	215=HDMI5
204=S-Video1		
205=S-Video2		

Web Panels - Control, List, and TV Control Panels



Control Panel

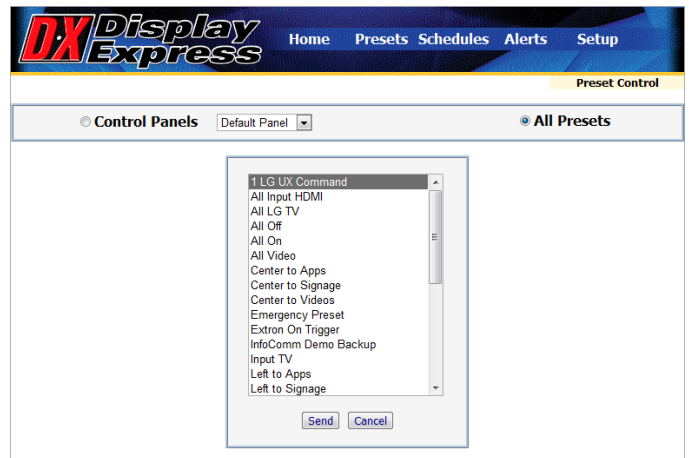

All Preset List



TV Control Panel

The **Control** page offers three ways to access Presets:

- **Control Panels** – Select from the Default or any number of custom control panels. The Administrator and System User can choose any panel created for any user.
- **TV Panels** – Select a Zone, Group, or specific TV to change channels, inputs, volume or power.
- **All Presets.** Sends a saved Preset group of commands to displays.

iPad/iPhone "App Icon"

On an iPad or iPhone, use Safari to access the site's DX Express web server. Login with the assigned User name and password, and all the DX Panels created for the user appear. A drop-down menu at the top of the page will select between assigned Panels. To turn those Panels into an App, click the "boxed arrow" button at the top left of the page, then select Add to Home Screen. You'll then have the option to name the app icon, and it will place the link on the phone that will open Safari to your personal Panel. In iOS, the link will appear to bypass the login, jump directly to the user panels. This is because in iOS, Safari never actually closes. If you turn off power, you'll need to log in again.

Control Panels – Control Panel Editing

DX Display Express Home Presets Schedules Alerts Setup

Setup Control Panels

Create New Panel
 Edit Existing Panel
 Copy Existing Panel

SmartPhone 1
SmartPhone 2
SmartPhone 3
Tablet

Control Panel

Name: Tablet

Rows: 8

Columns: 3

Font Size: Regular

Presets: (Select a Preset, then click on a button) 1 LG UX Command

Buttons:

- Left to Apps
- Center to Apps
- Right to Apps
- Left to Signage
- Center to Signage
- Right to Signage
- Left to Videos
- Center to Videos
- Right to Videos
- Matrix Preset
- Center to HDMI
- Weather Alert
- All On
- Mute All
- Lock All
- All Off
- Unmute All
- Unlock All

To create the Control pages, click on Setup, then Panels. That brings up the setup Panel page.

As with other editing functions in DX, you can:

- Create a new panel
- Edit an existing panel
- Copy an existing panel (handy when pages are only slightly different or use a similar layout)

Formatting

- You can select a layout of up to 25 rows and 4 columns. Click **Change Layout** once you selected the rows and columns you want.
- Next, click the Font Size. This will set the font as you add buttons. Also, if you switch fonts when you're finished, it will change the fonts in all buttons.

Adding Buttons

- Use the "Click on a button to assign it to this button" **Preset** menu to select a Preset
- Click on a button to assign the Preset to the button.
- To remove a Preset from the button, select Clear Button, then click a button. It's also a fast way to remove several buttons – just keep on clicking.

Presentation

Use blank buttons to create spaces between rows.

Control Panels - TV Panel Editing

DX Display Express Home Presets Schedules Alerts Setup

Setup TV Panels

Create New Panel Edit Existing Panel Copy Existing Panel

Left TVs
TV Control A

TV Panel Rows: 10 Columns: 3

Name: Left TVs Font Size: Regular Large Extra Large

Clear Button Large Displays: Large Displays All: All 232-ATSC+ (258)

Groups (Select a Group, then click on a button) Zones (Select a Zone, then click on a button) Displays (Select a Display, then click on a button)

L Back 1	L Side 1	L Front 1	Reserved for Channel and Volume control
L Back 2	L Side 2	L Front 2	
L Back 3	L Side 4	L Front 3	
	L Side 5	L Front 4	
Left Displays		L Front 5	
All		L Front 6	

Creating TV Control panels is similar to Control Panels, the difference is you are defining buttons that represent a Zone, Group, or individual TV.

As with other editing functions in DX, you can:

- Create a new panel
- Edit an existing panel
- Copy an existing panel (handy when pages are only slightly different or use a similar layout)

Formatting

- You can select a layout of up to 25 rows and 3 columns. Click **Change Layout** once you selected the rows and columns you want.
- Next, click the Font Size. This will set the font as you add buttons. Also, if you switch fonts when you're finished, it will change the fonts in all buttons.

Adding Buttons

- Select a Zone, Group or Display
- Click on a button to assign the TV to the button.
- To remove a TV from the button, select Clear Button, then click a button. It's also a fast way to remove several buttons – just keep on clicking.

Control Panels – Assigning Users to Panels

The screenshot displays the 'Setup Users' interface in the DX Display Express software. At the top, there is a navigation menu with 'Home', 'Presets', 'Schedules', 'Alerts', and 'Setup'. The 'Setup Users' section is highlighted. Below the navigation, there are three radio buttons: 'Create New User', 'Edit Existing User' (which is selected and highlighted with a yellow box), and 'Copy Existing User'. To the right of these buttons is a dropdown menu showing a list of users: 'Admin', 'iPhone', 'Sys User', and 'Tablet'. Below this is a 'User' form with the following fields and options:

- Name:** A text input field containing 'iPhone'.
- Password:** A text input field, currently empty.
- Role:** Three radio buttons: 'System Administrator', 'System User', and 'Panel User' (which is selected).
- Default Panel:** A dropdown menu showing 'Left TVs'.
- Buttons:** 'Save' and 'Delete' buttons are located at the top right of the form.
- Panel Lists:** At the bottom, there are two lists: 'User's Panels' (containing 'Left TVs' and 'Right TVs') and 'All Panels' (containing 'Default Panel', 'Left TVs', and 'Right TVs'). An arrow button is used to move items from 'All Panels' to 'User's Panels', and an 'X' button is used to remove items from 'User's Panels'.

This page can be used to create login names and passwords for Administrators and Users with System-wide access. DX 5.0 features a new class of users – Panel Users. This class of users can only access custom control panels when they login to the server. A System admin or System user can create and see all the control pages, as well as Presets, Schedules, and System features. The types of User access are:

- **System Administrator** – access to all features and DX Panels
- **System User** – access to first panel in each section, all DX Panels, but no editing options
- **Panel User** – can only access DX Panels assigned to the user name

Assigning pages to Panel Users

- Create a user Name and Password (leave Password blank if you want to).
- Highlight a panel on the right list, then click the arrow button to add the panel to the user.
- Highlight a panel name in the user's list, then click the "X" button to remove from a user.

When a Panel User logs in to DX, they will only see the panels assigned. A pull-down menu at the top of the page will allow the user to select from multiple pages.

Presets – Macros

A totally new feature to Display Express, this option is actually brought forward from the older IC Commander software. Macros contain the same control option used in creating basic Presets. The difference is that you can now save the group of commands by name, and reuse them in making Presets – this saves having to re-enter them when you create Presets.

To start, select:

- **Create New Macro** – Clears values in the Macro fields.
- **Edit Existing Macro** – Fills in the values from the selected Macro. Change and Save.
- **Copy Existing Macro** – Copies the values from the selected Macro. Change and Save.

Then select (click the checkbox at the left to include the values in the Macro):

- **Power** - Set Power On or Off.
- **HDTV Channel** – Enter HDTV channel in dashed (XX-X) or CableCard format (XXXXX)
- **NTSC Channel** – Enter desired analog channel (digital TVs will ignore this Preset)
- **Volume** - Set volume level 0 (Mute) to 63 (Full)
- **Control Lock** - Enable or disable display's front-panel and IR control (not all sets have this feature)
- **Tune Ring** – For legacy analog Smart TV control, defines list of channels accessible by user
- **Save/Restore** - Allows you to create and schedule Alerts. When **Save** is included, the display controllers will remember the power state and channel, then activate the new commands in the Preset. See page 18 for more information.
- **Command String**. See the Preset-Edit – Macros or Commands section for more information

To test the Macro, select a Display Group, Zone, Name or number, and click **Send**.

For basic DX applications, you don't need to create Macros, just add the control commands when you create the Preset. In more complex systems, especially for Advanced Presets, macros can be very helpful.

Presets– Edit

The Display Edit page offers the ability to create, copy, or edit new display control Presets. Display Express assigns control Presets to three entities:

Editing Modes

- **Create New Preset** – Clears values in the Preset fields.
- **Edit Existing Preset** – Fills in the values from the selected Preset. Change and Save.
- **Copy Existing Preset** – Copies the values from the selected Preset. Change and Save.

Displays

- **Group** – Send preset to a named group
- **Zones** – All displays for all or one of 15 Zones respond to a single Preset
- **Display** – Selects display by name (see Displays-Names)
- **Display#** – Selects a display by entering an address

Operations

- **Save** – Saves Preset
- **Delete** – Delete Preset
- **Send** – Sends Preset for testing operation

Manual Control

In addition, you can select any Group, Zone, and Display, then enter a command on the right, then click SEND to send a command without saving as a Preset, or testing a Preset before saving.

Macros or Commands

- **Use Macro** – Choose from a list of named control commands
- **Use Commands** – Enter commands from list below

Add or change values to an existing or new Preset. Parameters that are checked on the left will be sent, those unchecked will not be saved or sent. You can start with selecting a Macro, then change one or two of the options in the Command window. The values in the original Macro won't be changed.

- **Name** – Enter a name for a new or copied Preset.
- **Zone** – Select from 15 Zones or All Zones.
- **Single Display** – use radio button to select a Preset to a specific display.
- **Power** - Set Power On or Off. Try not to include Power On with every Preset, use it to power on the displays at the beginning of the event or day. The controllers have built-in delays after power on, as display often can't receive other commands during power-up.
- **HDTV Channel** – Enter HDTV channel in dashed (XX-X) or CableCard format (XXXXXX)
- **NTSC Channel** – Enter desired analog channel (digital TVs will ignore this Preset)
- **Volume** - Set volume level 0 (Mute) to 63 (Full)
- **Control Lock** - Enable or disable display's front-panel and IR control (not all sets have this feature)
- **Tune Ring** – For legacy Smart TV control, defines list of channels accessible by user
- **Save/Restore** - Allows you to create and schedule Alerts. When **Save** is included, the display controllers will remember the power state and channel, then activate the new commands in the Preset. When Restore is included, the controllers will return to the previous channel and power state. Also include a Volume setting with a Restore command to return the sets to a new audio level. The controllers don't store volume level with Save.
- **Command String.** In addition to typical display commands, there are other rarely used IC-Net commands that can be sent when needed, provided with system documentation. This includes:
 - Set display code - instructs a controller to use a different set of control codes for a different make and model of display.
 - Test basic display operation before presets have been defined. Select a Zone, Group, a named display, or a display address. Then enter
 - P1 turns power on
 - P0 turns power off
 - TC, nnn tunes in an analog channel (TC,33) tunes in channel 33
 - TH,nnn,nnn tunes in a digital channel (TH,15,1 tunes in channel 15-1
 - Other special commands are listed on the next page
 - Make – specific commands
 - LG Typical format will be UX,'kc 0 2',13 (command sets TV to 16:9 ratio). Refer to the set's manual for other commands. For most, you will change the values for the command (kc) and the data (2).
 - Sharp has a similar (but different) format: UX WIDE9 ,,\$0D for the standard Full wide screen command.

The chart below covers the most common commands that can be sent via the Special Commands tool. Many more are available from the product manual or product page at www.crwww.com. Some commands can be sent with no other information, such as P1 for Power On. Most other commands need an added parameter, such as volume level or control type.

Command	Description	
All Controllers		
Power Off	P0	
Power On	P1	
Tune Analog	TC,	2-127 Example: TC,33
Tuning Format All	S0,	0=CATV 1=Off-Air 2=IRC 3=HRC 4=Auto
Volume	VL,	Sets TV volume level 0 = Mute 1 – 63 = Minimum level (1) to maximum volume (63)
RS-232		ICC1-232, ICC2-ATSC, ICC2-VDC
Tuning Style ICC1-232	H1=	1 = 5-digit CableCard style tuning (1-9999) 2 = Virtual HD Major-Minor tuning (tunes to virtual channel ID in display) 3 = Physical HD Major-Minor tuning (physical channel, minor digital)
HD Tuning	TH,	<Major>,<Minor> Example: TH,15,1 tunes channel 15-1
HD Tune Style ICC1-232	TH,	<Style>,<Major>,<Minor> Once a Style parameter is included in tuning command, the ICC1-232 will stay in that mode until the Style is changed <Style> 0=No change in tuning style 1=5 digit channel (Major=high byte, Minor=low byte) 2=Virtual channel (Major-Minor) 3=Physical channel (Major=Physical - Minor=minor) Example: TH,3,15,1 tunes the digital channel physically broadcasting on 15 The ICC2-ATSC always tunes the virtual channel
IR		ICC1-IR, ICC2-IRC
IR Code	T1,	Sets IR control code. Check Manual or www.crwww.com product Install page for codes

Presets – Advanced Presets

DX Display Express Home Presets Schedules Alerts Setup

Preset Advanced Edit

Create New Preset Edit Existing Preset Copy Existing Preset

Click 'Add Preset to List Below' and then select a preset to add. Or click '+' for an empty row, then Set Displays and Set Commands.

Left to Apps
Left to Signage
Left to Videos
Lock All
Matrix Preset
Mute All

Add Preset To List Below

Preset Name: Matrix Preset Save Delete Clear

Displays	Macro	Power	HDTV	NTSC	Vol	Lock	Other	Delay
<input checked="" type="checkbox"/> SB 1	Comcast 1		Comcast 1					
<input type="checkbox"/> SB 2	Comcast 2		Comcast 2					
<input type="checkbox"/> SB 3	ESPN 1		ESPN 1					
<input type="checkbox"/> SB 4	ESPN 2		ESPN 2					
<input type="checkbox"/> SB 5	TICK 2		Ticket 2					
<input type="checkbox"/> SB 6	TICK 3		Ticket 3					
<input type="checkbox"/> SB 7	DRTV 11		DRTV 11					

Set Displays Group Zone Display Display #

Large Displays
SB 1
SB 2
SB 3

All Zones
Right Displays
Left Displays
Center Displays

232-ATSC+ (258)
ATSC TV (513)
Center TV (769)
LG TV (257)

1 - 4094

Set Commands Use Commands Use Macro Set Delay Remove Delay

Comcast 1
Comcast 2
DRTV 11
DRTV 2

1 to 999 10ths of a second

Show Commands Below

Most Presets will be created as a single command, as shown on the previous page. In version 3.0 and above, you can also create a multi-step preset. There are several key applications to this feature:

Creating a “Matrix” Preset

This type of multi-step preset can create an array of displays and channels. For example, a sports bar may want to set up a group of displays to present a pattern of channels. The Preset above was created with this process:

- Beforehand, the user creates a series of Macros for each channel, and seven groups of displays, each group including two displays.
- Click **Show Commands** in the **Macro** section to display or hide the **Command** section (see the next page for that image).
- Click on **Presets – Adv Edit**, then click the “+” button at the right to enter the first line.
- Select a **Group** of displays (could be a Zone or individual display as well).
- Click a **Macro**, then click **Set Macro**. Notice that the row will show what commands are in the Macro.
- If you want to add a time delay between rows, enter a delay time and use **Set Delay** to add the delay.
- Click “+” to start the next row.
 - You could create the array of displays first, then go back and select the Macro for each display.
 - Note that when a row is active for editing, it will turn red.
 - You can also add a Preset to the list.
- You can also use Add Preset to insert a single or multiple Presets into the list. Once the Preset is added, you can change Displays, Macros, or Commands as you need.
- If you want to re-arrange the list, select a row and use the Up and Down arrows on the right to move.
- Enter a name and **Save**.
- Once you have the matrix defined, you can use **Copy Existing Preset**, change the Macros and save the new array by a new name.

DX Display Express Home Presets Schedules Alerts Setup

Preset Advanced Edit

Create New Preset Edit Existing Preset Copy Existing Preset

Click 'Add Preset to List Below' and then select a preset to add. Or click '+' for an empty row, then Set Displays and Set Commands.

Input TV
Left to Apps
Left to Signage
Left to Videos
Lock All
Matrix Preset

Add Preset To List Below

Preset Name: Matrix Preset [Save] [Delete] [Clear]

Displays	Macro	Power	HDTV	NTSC	Vol	Lock	Other	Delay
<input checked="" type="checkbox"/> SB 1	Comcast 1		Comcast 1					
<input type="checkbox"/> SB 2	Comcast 2		Comcast 2					
<input type="checkbox"/> SB 3	ESPN 1		ESPN 1					
<input type="checkbox"/> SB 4	ESPN 2		ESPN 2					
<input type="checkbox"/> SB 5	TICK 2		Ticket 2					
<input type="checkbox"/> SB 6	TICK 3		Ticket 3					
<input type="checkbox"/> SB 7	DRTV 11		DRTV 11					

< >

Set Displays Group Zone Display Display #

Large Displays
SB 1
SB 2
SB 3

All Zones
Right Displays
Left Displays
Center Displays

232-ATSC+ (258)
ATSC TV (513)
Center TV (769)
LG TV (257)

1 - 4094

Set Commands Use Commands Use Macro [Set Delay] [Remove Delay]

Comcast 1
Comcast 2
DRTV 11
DRTV 2

1 to 999 10ths of a second

Show Commands Below

Power On Off

HDTV Channel Channel Comcast 1 (25-1) Channel # e.g. 14-1

NTSC Channel Channel Apps (65) Channel # 2 - 127

Volume 0 (Mute) - 63 (Full)

Control Lock On Off

Tune Ring 5-8 Tune

Save/Restore Save Restore

Command String

If you want to create the array with Commands alone, click **Use Commands** and **Show Commands** in the Macro section and enter the commands as needed.

Editing is seamless between Macros and Commands. When you use a Macro, all the values are shown in the row. You can switch to Commands and change one value, such as Volume, without needing to change the macro. In that case, the Macro name will go away, but all the values from the macro will be kept.

The **Show Commands** option is also useful if you want to see what commands are stored inside a Macro.

Controlling Power and Startup Delays.

Once a display is powered on, there is often some delay before the display is ready to listen to another command. Our controllers know this, and have a built-in time delay before they send commands included with power on. It's a great feature, but don't include Power On commands in a multi-step Preset. Since some sets LGs need to wait 8 seconds after power, it slows the process down.

The better plan is to power up the displays at the beginning of the event or day. Then use Presets with the other commands after that.

Presets – System

The screenshot shows the 'System Preset' configuration page in the DX Display Express software. At the top, there is a navigation bar with 'Home', 'Presets', 'Schedules', 'Alerts', and 'Setup'. The main content area is titled 'System Preset' and contains several sections:

- Actions:** Three radio buttons: 'Create New Preset', 'Edit Existing Preset' (highlighted with a yellow box), and 'Copy Existing Preset'.
- Presets List:** A dropdown menu showing 'Backup Minimal' and 'System Backup'.
- System Status:** A box showing 'System Currently In Use: Sys2012-03-19_1202', 'Backup Date/Time: 3/19/2012 1:59 PM', and 'Changes Made: No'.
- System Preset Form:** A form with the following fields:
 - System Preset:** Title with 'Save', 'Delete', and 'Do Now' buttons.
 - Preset Name:** Text input field containing 'Backup Minimal'.
 - Backup System using:** Radio button selected.
 - Default System Name:** Text input field containing 'e.g. Sys2009-10-22_1410'.
 - Overwrite Existing System:** Radio button selected, with a dropdown menu showing 'Minimal'.
 - New System Name:** Text input field.
 - Restore System:** Radio button, with a dropdown menu showing 'Minimal'.
 - Delete System:** Radio button, with a dropdown menu showing 'Minimal'.

This section allows you create a System Preset that can back up or restore all system data.

You can schedule an automatic backup as with any Control Preset, choosing a cycle, dates and times. You can also perform a manual backup or restore, just click the **Do Now** button, or **Save** the preset, and launch the process as with any other Preset.

Within the Preset, you can:

- **Backup System** to a default or custom name. The Default name will combine the year, date, and time (in military format). As an option, you can create your own name.
 - Note that the Default name format will create a unique backup folder when the backup is scheduled.
 - When you use Overwrite Existing System, the scheduled backup will overwrite the previous data.
 - Creating your own System Name will not overwrite the data if that system already exists.
 - The backup files are stored in the Program Files/Contemporary Research/SignStream DX Service/Data folder, stored in a folder with the Backup System name you selected.
- **Restore System** – Choose a System file. This will replace the current data when activated. Normally, you would use Do Now.
- **Delete System** – Choose a System file. This Event will delete that System folder when scheduled or using Do Now.

External Presets

The screenshot shows the 'External Preset' configuration page in the DX Display Express software. At the top, there is a navigation bar with 'Home', 'Presets', 'Schedules', 'Alerts', and 'Setup'. The main content area is titled 'External Preset' and contains the following elements:

- Three radio buttons for preset management: 'Create New Preset', 'Edit Existing Preset' (which is selected and highlighted with a yellow box), and 'Copy Existing Preset'.
- A dropdown menu showing the selected preset name: 'Extron On Trigger'.
- A form titled 'External Preset' with buttons for 'Save', 'Delete', and 'Send'. It includes:
 - A text field for 'Name' containing 'Extron On Trigger'.
 - Radio buttons for 'RS232' and 'IP'. The 'IP' option is selected.
 - For 'RS232': a 'Baud Rate' dropdown set to '19,200' and a 'COM Port' text field with 'e.g. 1' as a hint.
 - For 'IP': an 'Address' text field containing '192.168.0.231' with 'e.g. 192.168.1.101' as a hint, and radio buttons for 'TCP' (selected) and 'UDP'.
 - A 'Port' text field containing '4010' with 'e.g. 4010' as a hint.
 - A 'Command String' section with instructions: '- Separate bytes or bytes and strings with commas.', '- Single-byte hex numbers are preceded by the '\$' symbol.', '- ASCII characters or strings are enclosed in single quotes.', '- Numbers not marked as hex or ASCII are a single decimal byte.' Below these is an 'Example: \$A5,\$0F,\$FF,6,'TN',18,'PBS'' and a text field containing 'on'.
 - A 'Delay After Sending' section with a text field and the label '1 to 999 10ths of a second'.

This is a feature requested by our integrators and clients. Imagine a facility that has many displays controlled over RF, but also has a number of video projectors controlled by Extron units. With External Presets, you can now send commands to the Extron controllers over IP, managing the projectors using Display Express presets and scheduling. External Presets can be included in any control panel or scheduled, just like any standard Preset.

In the example of Extron controllers, you will likely program the units to act on a "trigger" string sent from Display Express. If you are the end user, you may need the help of an AV integrator in setting up commands for external systems and controllers.

Schedule - Control

DX Display Express Home Presets Schedules Alerts Setup

Schedule Control

Current Schedule CR Demo Enabled Disabled Show Today's Events All Events

Preset	Time	Start	End	Days	Device	Power	HDTV	NTSC	Vol
All On	9:00 AM	10/25/2010		MTWRF	All Zones	On			
Left to Apps	9:01 AM	10/25/2010		MTWRF	Left Displays			Apps	
Center to Videos	9:01 AM	10/25/2010		MTWRF	Center Displays		Videos		
Right to Signage	9:01 AM	10/25/2010		MTWRF	Right Displays		Signage		
Right to Videos	11:00 AM	10/25/2010		MTWRF	Right Displays		Videos		
Left to Signage	11:00 AM	10/25/2010		MTWRF	Left Displays		Signage		
Center to Signage	11:00 AM	10/25/2010		MTWRF	Center Displays		Signage		
Left to Videos	1:00 PM	10/25/2010		MTWRF	Left Displays		Videos		
Right to Signage	1:00 PM	10/25/2010		MTWRF	Right Displays		Signage		
All Off	6:00 PM	10/25/2010		MTWRF	All Zones	Off			

< >

Schedules CR Demo 8/12/2011 10:39 AM

The Schedule Control page launches Events by date or recurring cycle. Events are similar to Presets, but include an assigned date, cycle, and time.

- **Schedule** displays the list of Events by date and time.
- **Enabled/Disable** – click to run or stop the schedule
- **Today's/All Events** – Displays just the events for today or all Events
- **Schedules** – Select from a list of saved schedules
- **Set Current Schedule** – set the selected schedule for current use

Schedule - Edit

The Schedule Edit page creates a database of Events. DX now allows you to create multiple Schedules, so you can have one list for daily operation, and others for holidays or special events.

Schedule Modes

- **Create New Schedule** – Allows creation of a new Schedule, clears values in data
- **Edit Existing Schedule** – Fills in the values of the selected Schedule. Change and Save.
- **Copy Existing Schedule** – Copies the values of the selected Schedule. Change and Save.
 - **Name Schedule** – create a name for a new schedule
 - **Save Schedule** – a red asterisk will appear to remind you to save any changes
 - **Delete Schedule**
 - **Export** - click the Export button at the top right of the page to export the schedule as a comma-separated data file, click the Export button at the top right of the page. This can be imported by a spreadsheet or other data program to arrange, display, and print as needed.

Schedule Preset

Schedules Presets by time. Date and recurring cycle.

- **Add** – Click when you are done to add Preset and time/date settings to schedule
- **Modify** – Click when you are done to modify the selected Preset'
- **Remove** – Removes Preset from schedule
 - **Select Preset** – selects the highlighted Preset
 - **One-Time** – Event is launched on one date only
 - **Recurring** – Check days of week for cycle
 - **Start Date** – When Event or cycle begins
 - **End Date** – When Event ends (removes Event from Schedule at 11:59 PM on specified day)
 - **Time** – AM or PM

DX will keep the cycle, Start Date, End Date, and Time values as you add new Presets to the schedule. This speeds up adding additional Presets – often, you only need to change the time values.

Alerts - Control

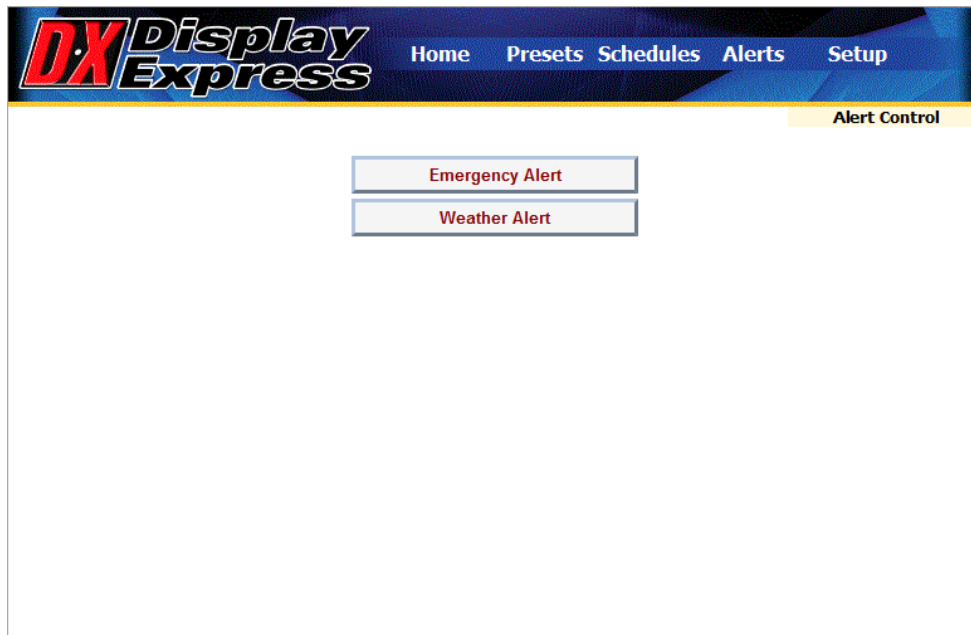

The **Alerts Control** page will display a group of up to 45 buttons a user can click to launch a saved Alert. The **Alerts Edit** page defines the name and actions in the alerts. The role of Alert Presets has expanded in DX 5:

- More than one Alert can be active at any time
- Alerts can be added to custom Web Panels, just like standard Presets
- The Alert text is in Red, and the button will change to orange when the alert is active, click the highlighted button to turn the Alert off

The Alerts feature can impact more than displays. An RS-232 controller or integrated tuner/controller can send a message to presentation room control systems, triggering a programmed response by the system.

In addition, an external control system can send Telnet commands that can trigger a saved Emergency Alert.

Alerts - Edit

DX Display Express Home Presets Schedules Alerts Setup

Alert Edit

Create New Alert
 Edit Existing Alert
 Copy Existing Alert

Emergency Alert
Weather Alert

Alert Save Delete

Name: Weather Alert

Preset: Tune Ring 5-8
Tune Ring All
Tune Up
Unlock All
UnMute All
Weather Preset

Volume after Alert: 20 (0 (Mute) - 63 (Full))

Suspend Schedule while Alert is in effect

The **Alerts Edit** page functions the same way as scheduling Events. However, Alerts behave differently than Events or Presets. When an Alert is sent, the iC-Net controllers will save their current power and channel settings. When an Alert ends, the controllers will return displays to their saved setting.

Editing Modes

- **Create New Alert** – Clears values in Alert fields.
- **Edit Existing Alert** – Fills in the values of the Alert command. Change and Save.
- **Copy Existing Alert** – Copies the values of the Alert Command. Change and Save.

Alert

- **Name** – Enter a name for a new or copied Alert.
- **Preset** – uses the values of a selected Preset, adds Save and Restore automation
- **Volume after Alert** – sets volume to set level after the Alert
- **Suspend Schedule** – deactivates scheduled presets when the Alert is active

Save the Alert. Up to 45 Alerts will appear on the Alerts Control page, and any Alert can be added to custom Web Panels.

Other systems can also trigger Alerts, sending a Telnet command to the DX computer. See **Telnet Commands** at the end of this manual.

Telnet Commands

As integrators have asked for tools to interact with Display Express from custom control systems, we have added several Telnet commands to our software. More commands will be added on request from our users and control partners.

Commands are case-insensitive, so upper or lower case may be used. Precede all commands with ']'.

Command	Description	Examples
?	Displays all DX TCP commands.]?
EF	Echo off]EF
EN	Echo on]EN
ID	Information on DX. <i>Reply:</i>]ID [present application [working directory [version
ServerInfo	Information on a DX server. <i>Reply:</i>]ServerInfo [server name [server description [version
SendPreset	Have the Head End send the specified preset.]SendPreset=Turn on All Displays
StartAlert	Have the Head End start a defined alert.]StartAlert=Fire Drill
StopAlert	Have the Head End stop an alert that is running.]StopAlert=Fire Drill
Quit	Close TCP connection.]Quit

Display Express TCP

To send commands to the Display Express server over the intranet using TCP/Telnet, do the following:

1. For HyperTerminal and other Terminal applications, enter the IP address of the Display Express server and 2728 as the Telnet port. Make sure the Windows Firewall exceptions include Display Express TCP, port 2728.
2. In a command window, type
telnet <name or IP address of Display Express server> 2728
For example, telnet CR Streams 2728. You should get a welcoming message.
3. Type Display Express TCP commands at the prompt. See above table of commands. For a list of commands, type ']?'. To stop, type ']quit'.

SSCmd

SSCmd.exe is found in C:\Program Files\Contemporary Research\SignStream DX Service\bin. It can be used to execute TCP-style commands in a command window or in a batch .cmd file. For example, to send a preset to the Head End, navigate to the \bin directory in a command window, and at the prompt type ">sscmd]sendpreset=Turn On All Displays"

Display Express Software

The product is protected by Federal Copyright Law. Contemporary Research retains the title to and ownership of the Product. You are licensed to use this Product on the following terms and conditions:

LICENSE - The licensee is defined as the individual or company utilizing the Software Product. Contemporary Research hereby grants the licensee a nonexclusive license authorizing the licensee to use the enclosed Product on one computer at a time. Please contact Contemporary Research if you require additional licenses. Use of this product by more than one individual or by anyone other than the licensee terminates, without notification, this license and the right to use this product. Web access from external browsers is unlimited.

YOU MAY NOT: Distribute, rent, sub-license or otherwise make available to others the software or documentation or copies thereof, except as expressly permitted in this License without prior written consent from Contemporary Research. In the case of an authorized transfer, the transferee must agree to be bound by the terms and conditions of this License Agreement.

RESTRICTIONS: - You may use this Product in your business as long as:
The software user must be registered with Contemporary Research in order to receive support or distribution rights. You may not remove any proprietary notices, labels, trademarks on the software or documentation.
You may not modify, de-compile, disassemble, reverse engineer or translate the software.

US GOVERNMENT RESTRICTED RIGHTS - Use, duplication or disclosure by the United States Government is subject to restrictions as set forth under DFARS 252.227-7013 or in FARS 52.227-19 Commercial Computer Software - Restricted Rights.

TERM - You may terminate your License and this Agreement at anytime by destroying all copies of the Product and Product Documentation. They will also terminate automatically if you fail to comply with any term or condition in this Agreement.

LIMITED WARRANTY - This software and documentation are sold "as is" without any warranty as to their performance, merchantability or fitness for any particular purpose. The licensee assumes the entire risk as to the quality and performance of the software. Contemporary Research warrants that the diskettes, CD, or emailed file on which the Program is furnished will be free from any defects in materials. Exclusive remedy in the event of a defect is expressly limited to the replacement of diskettes. In no event shall Contemporary Research or anyone else who has been involved in the creation, development, production, or delivery of this software be liable for any direct, incidental or consequential damages, such as, but not limited to, loss of anticipated profits, benefits, use, or data resulting from the use of this software, or arising out of any breach of warranty.

Contemporary Research

4355 Excel Pkwy, Suite 600, Addison, TX, 75001
Phone: 888-972-2728