

# Product Manual

## ICC-HE / ICW-HE

---

Head-End Network Controller  
Ver. 2.3 September 23, 2003



17630 Davenport Rd, Suite113  
Dallas, TX 75252 USA

Tel: 972.931.2728  
888.972.2728

Fax: 972.931-2765

Web: [www.crwww.com](http://www.crwww.com)  
[www.contemporaryresearch.com](http://www.contemporaryresearch.com)

# Table of Contents

---

<b>Overview</b> .....	<b>3</b>
<b>Specifications</b> .....	<b>4</b>
Physical .....	4
Front Panel .....	4
Control Connections.....	5
iCW-Net Connections (ICC-HE and ICW-HE) .....	5
iCC-Net Connections (ICC-HE Only).....	6
Power Connections .....	6
Includes .....	6
<b>Installation</b> .....	<b>7</b>
RF Coax and iCC-Net Operation (ICC-HE Only).....	7
AC Power and Net LED operation.....	7
iCW-Net Connection (ICC-HE and ICW-HE).....	8
Remote Control Connection.....	8
I/O Port Connection.....	8
<b>RS-232 Terminal Commands</b> .....	<b>9</b>
<b>RS-232 Control Protocol</b> .....	<b>10</b>
Overview .....	10
Command String Structure .....	10
Command format .....	10
<b>RS-232 HE Commands</b> .....	<b>11</b>
<b>RS-232 Device Commands</b> .....	<b>12</b>
<b>RS-232 Response</b> .....	<b>18</b>
Response String Structure.....	18
<b>RS-232 HE Response</b> .....	<b>19</b>
<b>RS-232 Device Response</b> .....	<b>20</b>
<b>iC-Net Zones</b> .....	<b>22</b>
<b>System Map</b> .....	<b>23</b>
<b>Typical RF and ICC-Net Signal Flow</b> .....	<b>24</b>
<b>RF Channel Frequencies</b> .....	<b>25</b>
<b>iCW-Net Wiring</b> .....	<b>26</b>
<b>Safety Instructions</b> .....	<b>27</b>
<b>Limited Warranty and Disclaimer</b> .....	<b>28</b>

# Overview

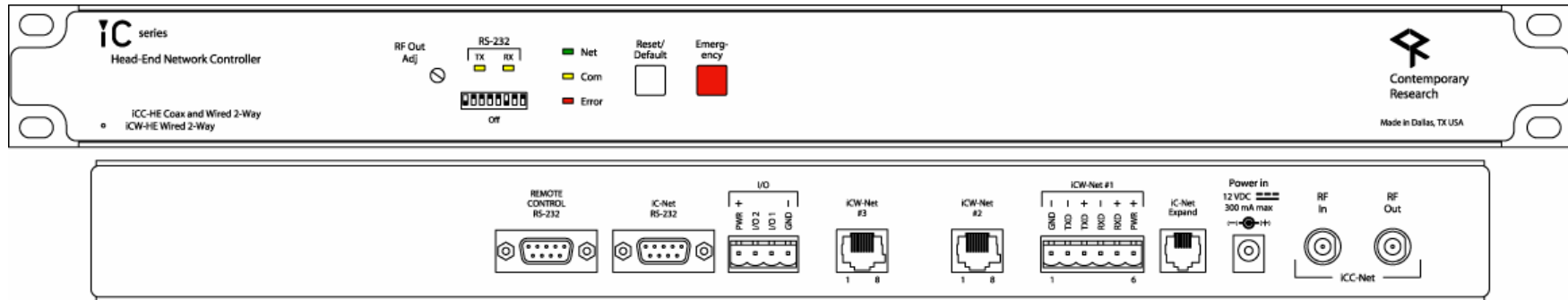

Contemporary Research (CR) offers two solutions for intelligent television control and distributed media management, the ICC-HE and ICW-HE Head-End Network Controllers. Both units are capable of networking up to 4,000 iC-Net TV Controllers, Display Controllers and Tuners into a unified, interactive system. The iC-Net network can be distributed over Category 3 or 5 wiring (iCW-Net) or over broadband RF coax (iCC-Net), communicating over the same CATV cable that carries the system's TV channels. ICW-series controllers deliver 2-way control and feedback over the iCW-Net wired network, while ICC2-series and ICC1-series controllers provide 2-way and 1-way control through the iCC-Net coax network.

The ICW-HE provides 2-way iCW-Net networking, distributing iC-Net commands and responses over Category 5 or 3 wiring. Three iCW-Net ports are included, each capable of connecting thousands of ICW-Net format controllers over wiring runs of up to 3,300 feet (1 Km). In addition, iCW-Net data can be sent to remote locations over fiber and video conferencing codecs.

The ICC-HE features the same iCW-Net capabilities as well as distributing iCC-Net data over the CATV cable. Employing clear-channel RF frequencies to transmit and receive data, the iCC-Net network is compatible with most CATV systems without conflict with existing channels. The bi-directional network operates over a standard low-split cable system, simplifying installation and support.

- Networks with up to 4,000 TVs through wired iCW-Net and broadband CATV iCC-Net networks
  - iCC-Net operates through same CATV coax as TV channels, requires no additional wiring
  - iCW-Net distributes data over Category 5 or 3 wiring, fiber optic cable, or codecs
- Sends commands to individual devices, zones, or all units from a single RS-232 port
- Interacts with CR ABC Media Retrieval Systems, iC Commander software, or custom control systems
- Includes local control buttons and I/O ports that can trigger events in PC software or control systems
- Provides LED feedback for network, control, and operation status

# Specifications



## Physical

Size: 19" [483mm] wide x 1.75" [38mm] height (1RU) x 9" [229mm] deep  
 Weight: 3 lbs [1.36kg]  
 Enclosure: All aluminum with durable black powder coat paint  
 Mounting: Shelf or 19" equipment rack (mounting brackets included)

## Front Panel

RF Out Adjust: Trims iCC-Net channel output, shipped set to +55 dBmV (max)  
 RS-232 TX LED: Yellow LED, lights when receiving RS-232 data on Remote Control RS-232 port  
 RS-232 TX LED: Yellow LED, lights when receiving RS-232 data on Remote Control RS-232 port  
 RS-232 DIP Switch: Sets RS-232 baud rate (9600 - 38.4K), 8 data bits, no parity, 1 stop bit  
 Selects high/low sensitivity for RF In signal

DIP	Off	On
1	RF In Low*	RF In High
2		
3		
4		
5		
6	Baud	
7	Baud	
8	Baud	

Baud	6	7	8
38,400	ON	ON	ON
19,200*	OFF	ON	ON
9,600	ON	OFF	ON
4,800	OFF	OFF	ON
2,400	ON	ON	OFF
1,200	OFF	ON	OFF

\*Default setting

Net LED: Green LED for iC-Net bus, flashes once per second if network is operating, device numbers expected agree  
 The LED will flash twice per second if the number of present and expected devices do not match  
 COM LED: Yellow LED blinks when a valid command is received or system response sent through the Remote Control RS-232 port  
 Error LED: Red LED indicates a problem within the unit  
 Reset/Default: White button sends press and release RS-232 response to PC software or control system  
 Emergency: Red button sends press and release RS-232 response to PC software or control system

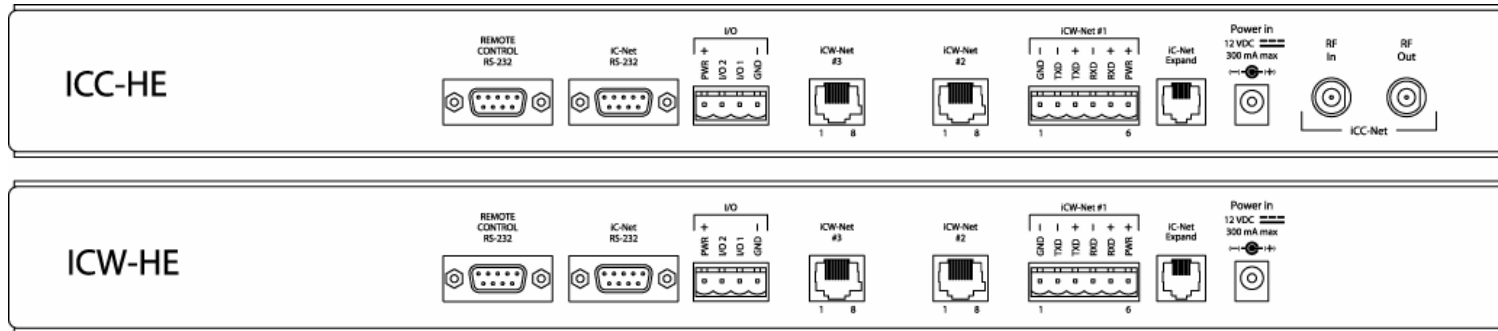

### Control Connections

Control RS-232: DB9 female, RS-232 data link to control system or PC

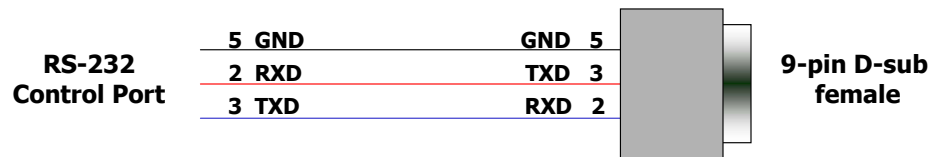

iC-Net RS-232: DB9 female, RS-232 data link to send iCW-Net over fiber or codec  
 I/O 1 & 2: 4-pin captive screw terminal for Input/Outputs 1 and 2  
 2 switch closures or inputs, max 50 mA, 24 VDC, switch to GND

- 1 – +12 VDC
- 2 – Output 2
- 3 – Output 1
- 4 – GND

I/O Applications: DC power – close pins 1 & 3 to provide DC on/off  
 Dry closure 2 – close pins 3 & 4 for dry contact to external power relay, AMX PC1 or similar  
 Sense closure (3 & 4) on Input 1 – trigger control system to power off for all rooms

### iCW-Net Connections (ICC-HE and ICW-HE)

iCW-Net 2, 3 RJ-45 female 8 pin Telco jack, supports 3300 ft [1 km] of wire

RS-422/485 type data requiring at least 2 twisted wire pairs with shield or fifth conductor

iCW-Net 1: 6-pin captive-screw terminal for system wiring or use with RS-422/485-format fiber or codecs

iC-Net Expand RJ-11 female 6-pin Telco jack

Recommended Wire: CAT5/CAT3 compatible unshielded, max 3,300 feet [1 Km] from Head End

**iCC-Net Connections (ICC-HE Only)**

RF In: 'F', female, 75 ohm impedance, RF and iCC-Net from CATV system  
Data Receive: Carried over the same RF coax connection as TV channels  
Return signal from system controllers  
Sub-band, 5.6MHz, narrow-band signal below standard sub-band channels  
-15 to +35 dBmV signal level (0 to +15 dBmV nominal)  
RF Out: 'F', female, 75 ohm impedance, RF to CATV distribution to TVs, tuners, and controllers  
Data Transmit: Mid-band VHF, 74.7 MHz, narrow-band signal between channels 4 and 5  
 $\pm 80$  KHz max carrier deviation  
+55 dBmV maximum (default)

**Power Connections**

Power In: 2.1mm coaxial jack (inside center conductor positive),  
11 to 18 VDC, 12 VDC typical, 300 mA maximum (may be unregulated)  
UL/CSA listed wall power supply (included for domestic 110 VAC/60 Hz shipments only)

**Includes**

10 dB RF attenuator  
12 VDC Power Supply

# Installation

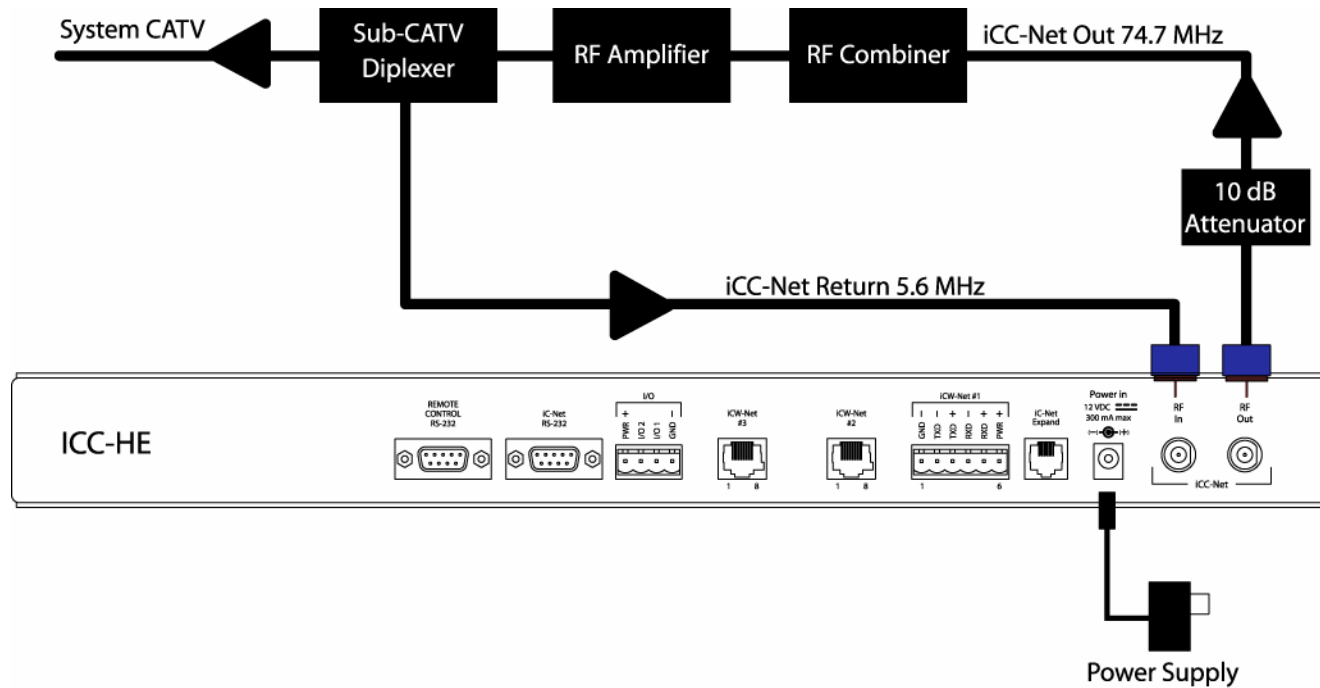

## RF Coax and iCC-Net Operation (ICC-HE Only)

1. Connect an RF coax feed from RF Out to the system's RF combiner, mixing the iCC-Net Out signal with the other CATV channels. The iCC-Net Out channel operates at 74.7 MHz, in between cable channels 4 and 5.
2. In most applications, you will connect the included 10 dB attenuator in between, trimming the He's standard 55 dB output to 45 dB.
3. Using an RF signal level meter, use the front panel RF Out adjustment counterclockwise to match the RF Out signal to the other CATV sources. Limit RF Out adjustment to -10 dB, using attenuators to achieve a lower signal strength.
4. Add a Sub-CATV Diplexer after the CATV amplifier.
5. Connect the Sub-Channel output of the Diplexer to the HE RF In connection.

## AC Power and Net LED operation

1. Insert DC power supply plug into the Power In jack.
2. Plug power adaptor into AC wall outlet, the front-panel LEDs should turn on momentarily.
3. If iC-Net communication is functioning, the Net LED will flash once per second, or twice per second (the double-flash, indicating a difference between present and expected device, would be typical in the initial phase of the installation.)

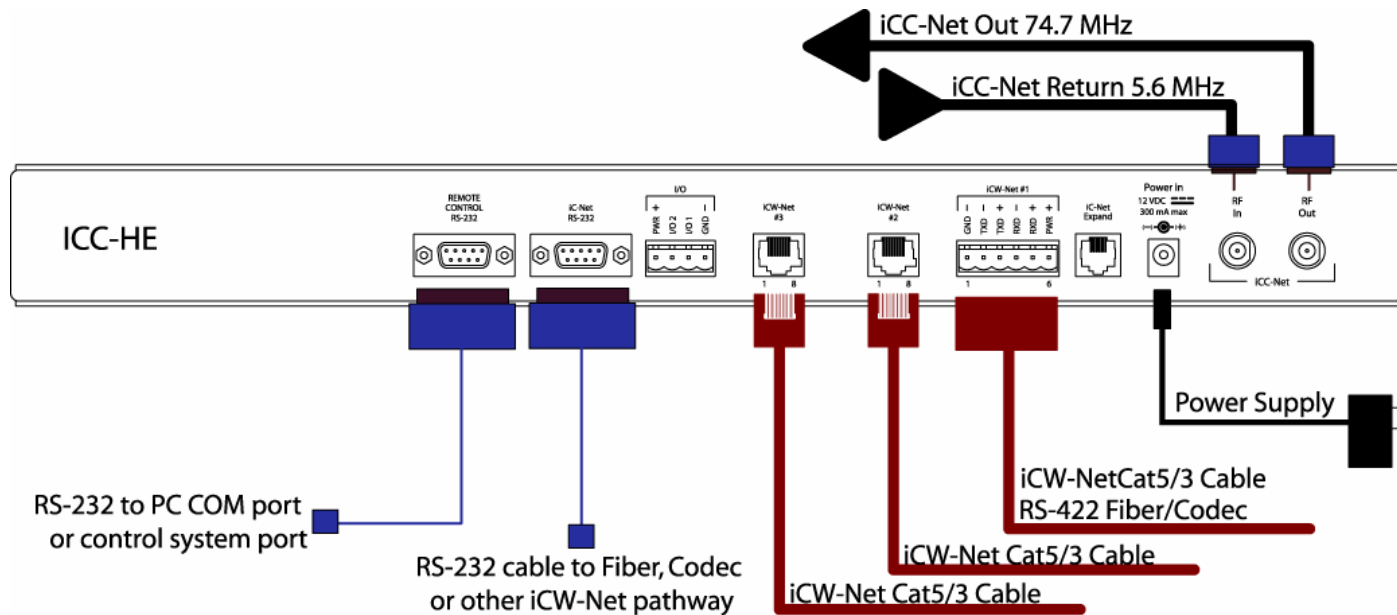

### iCW-Net Connection (ICC-HE and ICW-HE)

1. Plug the iCW-Net RJ-45 plug into the iCW-Net jack 2 or 3. Each iCW-Net port can support cable runs of up to 3,300 feet of wire. See iCW-Net Wiring for wiring structure and alternatives.
2. The iCW-Net port 1 uses a removable screw terminal (included) for wiring to Cat3/5 or RS-422/485 connections to fiber optics or codecs. Call Contemporary Research to coordinate use of fiber optic equipment. Each make and model often requires different wiring and electronic solutions for proper operation.
3. The iC-Net RS-232 port is used to extend iCW-Net control to remote locations through fiber, codecs or other RS-232 format equipment. The equipment at the remote end will need an RS-422/485 adapter to provide iCW-Net networking. See page 4 for RS-232 cable wiring diagram.

### Remote Control Connection

1. Attach appropriate RS-232 cable to Remote Control RS-232 port. See page 4 for RS-232 cable wiring diagram.
2. Set desired baud rate on front-panel DIP switch. Default setting is 19.2K baud – see page 4 for DIP switch setting information.

### I/O Port Connection

1. A simple contact closure can be wired to I/O 1 or 2, a press or release can trigger events in the PC or control system software.
2. In other applications, the I/O ports can act as closure outputs, activating an external power relay, 2x1 video switcher or other device.
3. You'll have to choose application – the ports act as either an output or input, not both. See **Control Connections** on page 4 for wiring and rating information.

# RS-232 Terminal Commands

---

Employ standard Windows Terminal program, set to baud rate match DIP switch setting on front of HE.

Command		Description
		<p>Commands shown in ASCII and end with carriage return (Decimal 13, Hex \$0D, or Enter key). Response displays * character to signify end of characters, or times out if no characters are received after 2 seconds.</p> <p><b>Tip:</b> Just hit <b>Enter</b> to repeat any Terminal command.</p>
<b>Echo Enable</b>	<b>EN</b>	Enables character echo so you can see typed characters on screen.
<b>Echo Disable</b>	<b>EF</b>	Disables terminal character display (default).
<b>Version</b>	<b>VE</b>	Displays HE software version.
<b>Reset</b>	<b>ZI</b>	Performs system reset.
<b>Show Devices</b>	<b>SD</b>	<p>Displays list of 2-way devices stored in HE memory. List can be created by iC Commander software, ABC-MRC software, or Scan and Build command below.</p> <p><b>Example Response:</b> Devs Present: 257-261 263 265-271*</p>
<b>Show Missing</b>	<b>SM</b>	<p>Displays list of missing 2-way devices (compared to HE memory list).</p> <p><b>Example Response:</b> Devs Missing: 262 -263 264*</p>
<b>Show Present</b>	<b>SP</b>	<p>Displays number of present devices and number of devices expected.</p> <p><b>Example Response:</b> Num Devs Present : 1 Num Devs Expected : 53</p>
<b>Scan and Show</b>	<b>SZ</b>	Scans iC-Net and displays list of all 2-way devices found (does not change HE memory).
<b>Scan and Build</b>	<b>Z^</b>	Scans iC-Net and saves list of all 2-way devices found into HE memory.
<b>Show Log</b>	<b>L</b>	Returns four hex bytes, separated by commas. If any of the bytes change as you repeat the command, there is likely an error in return communication from iC-Net devices.
<b>Clear Log</b>	<b>DL</b>	Clears the L hex bytes to zero.

# RS-232 Control Protocol

---

## Overview

RS-232 control for up to 4000 iC-Net devices is provided through an iC-series Head-End Network Controller. The ICC-HE Head-End manages iC-Net communication over RF Coax to ICC-series devices as well as ICW-series devices over twisted-pair Cat3/5 wiring. The ICW-HE Head-End operates on the Cat5 network only.

Each device is assigned a unique device number from 1 to 4000 to which control commands are addressed. The devices are organized into 16 zones of 255 devices. All the devices in each zone will respond to a single "virtual device number" — one device number that represents all devices in each zone. There is also a global device number, 4095, that will command all devices in the system. This feature dramatically speeds up system operation and programming, because one command can affect an entire group of devices—or all. To take advantages of this feature, review the section **iC-Net Zones** in this manual.

In ABC Media Retrieval Systems, we reserve the first group of devices, 1-255, for components operating on a connected control system. Zones 1-16 are used for CR TV Controllers, Video Display Controllers and Tuners. As it's unlikely any system will use all 4000 devices, this may be a good device standard for your system as well.

The Remote RS-232 port on the Head-End Network Controller can communicate from 1200 to 38.4K baud. The factory default setting is 19.2K baud, 8 data bits, No parity, and 1 stop bit.

## Command String Structure

Characters in command strings are expressed in a combination of hex and ASCII characters.

- Single-byte hex numbers are preceded by the '\$' symbol
- ASCII characters or strings are enclosed in single quotes
- Numbers not marked as hex or ASCII are a single decimal byte
- Parameters shown in < > brackets are single byte
- A series of multiple commands or parameters are set apart by [ ] brackets
- Commas separate the bytes, but are not part of the protocol
- Double quotes enclose the command string, but are not part of the protocol

## Command format

"\$A5,<dh>,<dl>,<ncb>,<cmd1>,<parameter> [<cmdN>]"

<b>\$A5</b>	Starts the command
<b>&lt;dh&gt;</b>	The zone or high order byte of the device
<b>&lt;dl&gt;</b>	The unit or low order byte of the device (0 for global zone)
<b>&lt;ncb&gt;</b>	The number of command bytes to follow
<b>&lt;cmd1&gt;</b>	The first command byte
<b>&lt;parameter&gt;</b>	Command parameters (not used by all commands)
<b>[&lt;cmdN&gt;]</b>	Multiple commands can be concatenated, with byte count added to <ncb>

## RS-232 HE Commands

---

The following commands apply to the HE only. Commands addressed to controllers are included with the Product Manual for the specific device.

Command		Description
<b>Closures</b>	<b>Y_</b>	<p>"\$A5,0,0,3, 'Y' &lt;I/O Port&gt;' " (7 bytes)</p> <p>Turns the two internal closures on and off. Closure 1 is typically used to control the optional buzzer, Closure 2 typically used to control an external camera power relay.</p> <p>"\$A5,0,0,3, 'Y10'" turns Closure 1 off  "\$A5,0,0,3, 'Y11'" turns Closure 1 on  "\$A5,0,0,3, 'Y20'" turns Closure 2 off  "\$A5,0,0,3, 'Y21'" turns Closure 2 on</p>
<b>Device Status</b>	<b>SP</b>	<p>"\$A5,0,0,2,'SP'" (6 bytes)</p> <p>Queries the Head-End for the number of devices present on the network and the number of devices expected.</p>

# RS-232 Controller Commands

The following commands summarize RS-232 commands to iC-Net controllers. There is a high degree of compatibility between Contemporary Research devices, most commands execute a similar action or response in nearly all units. Refer to each unit's Product Manual for specific programming information.

Command	Description	ICC/W IRC	ICC2 VDC	ICW VDC	ICC ICW	PSC ZS2	ICC1 IR
<b>Power Off</b>	<b>PO</b> "\$A5,<dh>,<dl>,2,'P0'" (6 bytes) – checks status for true power control	<b>X</b>	<b>3</b>	<b>3</b>	<b>X</b>	<b>X</b>	<b>X</b>
<b>Power On</b>	<b>P1</b> "\$A5,<dh>,<dl>,2,'P1'" (6 bytes) – checks status for true power control	<b>X</b>	<b>3</b>	<b>3</b>	<b>X</b>	<b>X</b>	<b>X</b>
<b>Power Toggle</b>	<b>PT</b> "\$A5,<dh>,<dl>,2,'PT'" (6 bytes) – checks status for true power control	<b>X</b>	<b>3</b>	<b>3</b>	<b>X</b>	<b>X</b>	<b>X</b>
<b>Operating Parameters</b>	<b>TM</b> "\$A5,<dh>,<dl>,3,'TM',<setting>" (7 bytes) Sets up key functions in the unit bit 7 – 3 = 0 bit 2 – Channel up/down operation, 0=Tune Ring, 1=Send IR Keypad response bit 1 – Numeric channel labels, 0=num labels off, 1=num labels on) bit 0 – Alpha channel labels, 0=alpha labels off, 1=alpha labels on	<b>X</b>	<b>X</b>	<b>X</b>	<b>1</b>	<b>1</b>	<b>2</b>
<b>Volume</b>	<b>VL</b> "\$A5,<dh>,<dl>,3,'VL',<vol level>" (7 bytes) Sets volume level 0 = Mute 1 – 63 = Minimum level (1) to maximum volume (63)	<b>X</b>	<b>X</b>	<b>X</b>	<b>X</b>	<b>X</b>	<b>X</b>
<b>Power-up Volume</b>	<b>S5</b> "\$A5,<dh>,<dl>,3,'S5',<volume>" (7 bytes) Sets volume level when IRC powers up 0 = restore to previous level 1 – 63 = Set from minimum (1) to maximum level (63)	<b>X</b>	<b>X</b>	<b>X</b>			
<b>Mono/Stereo</b>	<b>S0</b> "\$A5,<dh>,<dl>,3,'S0', <mode>" (7 bytes) 0=mono, 1=stereo			<b>X</b>			
<b>Bass Gain</b>	<b>S7</b> "\$A5,<dh>,<dl>,3,'S7', <mode>" (7 bytes) Sets bass gain			<b>X</b>			
<b>Treble Gain</b>	<b>S9</b> "\$A5,<dh>,<dl>,3,'S9', <mode>" (7 bytes) Sets treble gain			<b>X</b>			
<b>Notes</b>	<b>1</b> 1-way models do not send a response (bit 2) <b>2</b> ICC1 does not provide channel labels or response <b>3</b> Sends discrete power on and power off commands						

Command	Description	ICC/W IRC	ICC2 VDC	ICW VDC	ICC ICW	PSC ZS2	ICC1 IR
<b>Display Control</b>	<b>T0</b> "\$A5,<dh>,<dl>,3,'T0'<type> " (7 bytes) – Sets RS-232 control codes Identical to on-screen menu <b>45700</b> command for VDC.		X	X			
<b>IR Device Type</b>	<b>T1</b> "\$A5,<dh>,<dl>,3,'T1'<type> " (7 bytes) – Sets IR device type Identical to on-screen menu <b>45700</b> command for IR-format controllers.	X					X
<b>Marquee Chan</b>	<b>T2</b> "\$A5,<dh>,<dl>,3,'T2'<channel> " (7 bytes) – Sets default power-up channel Sets default channel selected when unit powers up	X	X	X	X		
<b>Ts &amp; Qs</b>	<i>The following T-series channel commands select a channel and display the channel label on the TV, while Q-series commands don't show the on-screen text.</i>						
<b>T Channel Up</b>	<b>TU</b> "\$A5,<dh>,<dl>,2,'TU' " (6 bytes) – Tunes to next channel up in Tune Ring	X	X	X	X	X	1
<b>T Channel Dwn</b>	<b>TD</b> "\$A5,<dh>,<dl>,2,'TD' " (6 bytes) – Tunes to next channel down in Tune Ring	X	X	X	X	X	2
<b>Force T Chan</b>	<b>TC</b> "\$A5,<dh>,<dl>,3,'TC', <channel>" (7 bytes) – Tunes to a specific channel  124 = RGB 2 input on TV 125 = RGB input on TV 126 = Select external A/V input (IRC/VDC also selects TV video input) 127 = Select S-Video Input 0 = Blank video output to TV 255 = Unblank TV video (restore to previous channel)  <b>Tip:</b> Not all inputs are available on every TV make and model.	X	X	X	X	X	2
<b>Select T Chan</b>	<b>TT</b> "\$A5,<dh>,<dl>,2,'QT',<channel>" (7 bytes) – Tunes channel if included in TR	X	X	X	X	X	2
<b>Channel Query</b>	<b>T?</b> "\$A5,<dh>,<dl>,2,'T?' " (6 bytes) – Request response for current channel	X	X	X	1	1	1
<b>Q Channel Up</b>	<b>QU</b> "\$A5,<dh>,<dl>,2,'QU' " (6 bytes) – Tunes to next channel up in Tune Ring	X	X	X	X	X	X
<b>Q Channel Dwn</b>	<b>QD</b> "\$A5,<dh>,<dl>,2,'QD' " (6 bytes) – Tunes to next channel down in Tune Ring	X	X	X	X	X	X
<b>Force Q Chan</b>	<b>QC</b> "\$A5,<dh>,<dl>,3,'QC', <channel>" (7 bytes) – Tunes to a specific channel  Same special-function channels as in the T Channel Select section above	X	X	X	X	X	X
<b>Select Q Chan</b>	<b>QT</b> "\$A5,<dh>,<dl>,2,'QT',<channel>" (7 bytes) – Tunes channel if included in TR	X	X	X	X	X	X
<b>Notes</b>	<b>1</b> 1-way models do not provide response <b>2</b> Does not provide channel label display, obeys both T and Q commands						

Command	Description	ICC/W IRC	ICC2 VDC	ICW VDC	ICC ICW	PSC ZS2	ICC1 IR
<b>Video Loss Detection</b>	<b>Q2</b> "\$A5,<dh>,<dl>,3,'Q2',<video loss mode>" (7 bytes) Selects response when a loss of video signal is detected  0=Both audio and video muted (default-blue screen for video) 1=Audio muted only 2=Video muted only 3=No muting (do nothing on loss of video)	X	X				
<b>Tuner Mode</b>	<b>SO</b> "\$A5,<dh>,<dl>,3,'S0',<tune mode>" (7 bytes)  Sets tuner mode to CATV or Broadcast/Antenna 0 = CATV 1 = Broadcast/Antenna 2 = HRC	X	X	X	X		
<b>Tune Ring</b>	<b>TR</b> "\$A5,<dh>,<dl>,<ncb>,'TR', [<chan 1>, <chan N>]" (variable bytes)  This command stores a Tune Ring, a series of preset channels accessed by channel up/down commands.  <b>Ex1:</b> "\$A5,<dh>,<dl>,6,'TR', 5,4,8,11" sets ring to channels 5, 4, 8 and 11 <b>Tip:</b> The ring follows the stored order, channels do not have to be in ascending order <b>Ex2:</b> "\$A5,<dh>,<dl>,2,'TR' " clears the Tune Ring, locks unit to current channel <b>Tip:</b> In the above mode, the IR Keypad channel up/down response to the Head-End, so the system will know the user is trying to change channels. In response, the system could change channels on a media sources, like a VCR or satellite. See K response note in <b>RS-232 Responses</b> . <b>Ex3:</b> "\$A5,<dh>,<dl>,8,'TR', \$82,5,\$87,11" sets channels 2-5 and 7-11. You can specify a range using MSB bit for the first channel; the next byte is the last.	X	X	X	1	1	1
<b>Channel Labels</b>	<b>TN</b> "\$A5,<dh>,<dl>,<ncb>,'TN',<channel>,<label>" (variable bytes)  Stores an ASCII string as the channel label. The text will appear briefly when the channel is selected, if the feature has been activated by TM command.  <b>Ex1:</b> "\$A5,<dh>,<dl>,3,'TN', '7', 'PBS' " unit displays PBS when 7 is selected <b>Ex2:</b> "\$A5,<dh>,<dl>,3,'TN', '7' " Clears alpha label for channel 7 <b>Ex3:</b> "\$A5,<dh>,<dl>,3,'TN',0,0" Clears all alpha labels	X	X	X	X	X	
<b>Display Label</b>	<b>TC</b> "\$A5,<dh>,<dl>,2,'TC' " (6 bytes) – Display current channel label for about 15 sec	X	X	X	X	X	
<b>Notes</b>	<b>1</b> 1-way units do not send the K keypad responses in Ex2.						

Command	Description	ICC/W IRC	ICC2 VDC	ICW VDC	ICC ICW	PSC ZS2	ICC1 IR
<b>Closures</b>	<b>Y-</b> "\$A5,<dh>,<dl>,3, 'Y' <I/O Port>' " (7 bytes) Turns the two internal closures on and off. Closure 1 is typically used to control the optional buzzer, Closure 2 typically used to control an external camera power relay.  "\$A5,<dh>,<dl>,3, 'Y10'" turns Closure 1 off "\$A5,<dh>,<dl>,3, 'Y11'" turns Closure 1 on "\$A5,<dh>,<dl>,3, 'Y20'" turns Closure 2 off "\$A5,<dh>,<dl>,3, 'Y21'" turns Closure 2 on	<b>X</b>	<b>X</b>	<b>X</b>	<b>X</b>	<b>X</b>	
<b>Control Lock</b>	<b>LM</b> "\$A5,<dh>,<dl>,3,'LM',<control>" (7 bytes) Locks out front panel and IR remote control functions.  Bit 7 Selects IR remote control operation (0=enabled, 1=disabled) Bit 6 Selects volume control operation (0=enabled, 1=disabled) Bit 5 - 1 Always 0 Bit 0 Selects front panel button operation (0=enabled, 1=disabled)	<b>X</b>	<b>X</b>	<b>X</b>	<b>X</b>	<b>3</b>	<b>2</b>
<b>Control String</b>	<b>UX</b> "\$A5,<dh>,<dl>,2+string length>,'UX'<string>" (variable bytes) Sends an RS-232 string (ASCII, decimal, or hex) directly to the TV display. Ex: "\$A5,1,2,6,'UX, 'PON', 13" Sends PON, followed by carriage return (device 258)		<b>X</b>				
<b>Device Status</b>	<b>SP</b> "\$A5,0,0,2,'SP'" (6 bytes) Queries the Head-End for the number of devices present on the network and the number of devices expected.	<b>X</b>	<b>X</b>	<b>X</b>	<b>1</b>	<b>1</b>	
<b>Notes</b>	<b>1</b> 1-way units do not respond to command <b>2</b> Locks out IR remote control only <b>3</b> Zenith ZS2 – bit 7 selects both IR and front panel control, bit 0 always zero value						

Command	Description	ICC/W IRC	ICC2 VDC	ICW VDC	ICC ICW	PSC ZS2	ICC1 IR
<b>Write Text</b>	<p><b>DM</b> "\$A5,&lt;dh&gt;,&lt;dl&gt;,&lt;ncb&gt;,'DM', &lt;start line&gt;,&lt;text color&gt;,&lt;background color&gt;,&lt;background&gt;,&lt;size and shadow&gt;,&lt;timeout&gt;,&lt;message bytes&gt;" (variable bytes)</p> <p>Clears current text, displays text message over video (default) or blank background. The built-in character generator can accept up to 40 characters of text (including carriage returns), 28 characters per line. Use a hex \$0D or decimal 13 in the text as a carriage return, which will advance CG to the next line, first space on the right.</p> <p>Start Line - 1-11  Text Color - 1-7= White  Text Background Color – 0-7=Transparent (no background)  Full screen background – 0=normal insert over video, 1=blank screen (blue)  Size and Shadow – 0-3=small text with drop shadow  Time-Out – 0=15-second display, 1=persistent  Persistent text stays on screen until the next DM, or new Menu or channel.</p> <p><b>Ex1:</b> "\$A5,&lt;dh&gt;,&lt;dl&gt;,10,'DM', 2,7,0,0,1,0,'TEST' " displays the word TEST on the second line, white text, inserted over video, small size with drop shadow, and timing out after 15 seconds.</p> <p><b>Ex2:</b> "\$A5,&lt;dh&gt;,&lt;dl&gt;,2,'DM' " clears on-screen display, also clears persistent text</p> <p>The IRC and VDC use white text and clear backgrounds when it receives a Text or Background Color parameter between 1 and 7, and accepts values 0-3 for text size and shadow. This allows compatibility with Smart TVs mixed in the same system that can display other colors and fonts.</p>	<b>1</b>	<b>1</b>	<b>1</b>	<b>X</b>	<b>X</b>	
<b>Notes</b>	<p><b>1</b> Unit will respond to all formatting commands, using white text on transparent background</p>						

Command	Description	ICC/W IRC	ICC2 VDC	ICW VDC	ICC ICW	PSC ZS2	ICC1 IR
<b>Advanced</b>	The following commands provide advanced CG text operation						
<b>Fast Write</b>	<b>DN</b> "\$A5,<dh>,<dl>,<ncb>,'DN', <text> " (variable bytes) Clears display, writes specified text starting at column 1, row 1. \$0D and hex \$EA, \$EB, \$DC, and \$DB can be included, operate same as matching commands below.	<b>X</b>	<b>X</b>	<b>X</b>			
<b>Write Here</b>	<b>DW</b> "\$A5,<dh>,<dl>,<ncb>,'DW', <text> " (variable bytes) Writes specified text starting at present cursor position. Accepts same Hex as DN.	<b>X</b>	<b>X</b>	<b>X</b>			
<b>Row, Column</b>	<b>DG</b> "\$A5,<dh>,<dl>,4,'DG', <row>, <column>" (8 bytes) Moves the cursor to the specified row and column position. If row is 0, then row will not be changed, and if column is 0, then column will not be changed.	<b>X</b>	<b>X</b>	<b>X</b>			
<b>Cursor Column</b>	<b>E7</b> "\$A5,<dh>,<dl>,3,'E7', <column>" (7 bytes) – sends cursor to specified column.	<b>X</b>	<b>X</b>	<b>X</b>			
<b>Cursor Row</b>	<b>E8</b> "\$A5,<dh>,<dl>,3,'E8', <row>" (7 bytes) – sends cursor to specified row.	<b>X</b>	<b>X</b>	<b>X</b>			
<b>Return</b>	<b>EB</b> "\$A5,<dh>,<dl>,2,'EB' " (6 bytes) Moves cursor down to the first column of the next row.	<b>X</b>	<b>X</b>	<b>X</b>			
<b>Clear All</b>	<b>EA</b> "\$A5,<dh>,<dl>,2,'EA' " (6 bytes) Clears display, sends cursor to column 1, row 1.	<b>X</b>	<b>X</b>	<b>X</b>			
<b>Clear to End</b>	<b>DC</b> "\$A5,<dh>,<dl>,2,'DC' " (6 bytes) Clear on-screen display from cursor to end of screen, position stays the same.	<b>X</b>	<b>X</b>	<b>X</b>			
<b>Clear Line</b>	<b>DB</b> "\$A5,<dh>,<dl>,2,'DB' " (6 bytes) Clear on-screen display from cursor to end of line, cursor position stays the same.	<b>X</b>	<b>X</b>	<b>X</b>			
<b>Clear Spaces</b>	<b>E9</b> "\$A5,<dh>,<dl>,3,'E9', <num spaces>" (7 bytes) Clears specified number of spaces, starting from cursor to the right.	<b>X</b>	<b>X</b>	<b>X</b>			
<b>Text Timeout</b>	<b>DQ</b> "\$A5,<dh>,<dl>,3,'DQ', <time>" (7 bytes) Sets screen timeout to specified time in seconds (1-254). If time is 0 or 255, any text on the screen will persist indefinitely, or until cleared.	<b>X</b>	<b>X</b>	<b>X</b>			

# RS-232 Response

---

Contemporary Research 2-way iC-Net devices will send a response over the network whenever there is there is a change in status or command from an IR remote or front panel.

## Response String Structure

Characters in response strings are expressed in a combination of hex and ASCII characters. For clarity, the following protocol examples use the following conventions:

- ASCII characters or strings are shown enclosed in single quotes
- Numbers shown that are not in single quotes are a single decimal byte
- Parameters shown in < > brackets are single byte
- A series of multiple commands or parameters are set apart by [ ] brackets
- Commas separate the bytes, but are not part of the protocol
- Double quotes enclose the command string, but are not part of the protocol

## Command format:

```
" '<',<dh>,<dl>,<nrb>,<rb1>, <para1> [<rbN>]"
```

'>'	Starts the response
<dh>	The zone or high order byte of the device
<dl>	The unit or low order byte of the device (0 for global zone)
<nrb>	The number of response bytes to follow
<rb1>	The first response byte
<para1>	Associated parameters, if any
[<rbN>]	Multiple responses may be included

# RS-232 HE Response

---

The following responses apply to the HE only.

Response		Description								
<b>Key-I/O</b>	<b>K</b>	<p>"`&lt;',0,0,2,'K',&lt;IR Key&gt;" (6 bytes)</p> <p>Sent when the Reset or Emergency buttons are pressed, or when I/O 1 or 2 receives a closure. PC software or a control system connected to the Control RS-232 port can receive the response and activate a programmed event.</p> <table border="0"> <tr> <td>101 = Reset button pressed</td> <td>229 = Reset button released</td> </tr> <tr> <td>102 = Emergency button pressed</td> <td>230 = Emergency button released</td> </tr> <tr> <td>103 = I/O 1 input closed</td> <td>231 = I/O 1 input opened</td> </tr> <tr> <td>104 = I/O 2 input closed</td> <td>232 = I/O 2 input opened</td> </tr> </table>	101 = Reset button pressed	229 = Reset button released	102 = Emergency button pressed	230 = Emergency button released	103 = I/O 1 input closed	231 = I/O 1 input opened	104 = I/O 2 input closed	232 = I/O 2 input opened
101 = Reset button pressed	229 = Reset button released									
102 = Emergency button pressed	230 = Emergency button released									
103 = I/O 1 input closed	231 = I/O 1 input opened									
104 = I/O 2 input closed	232 = I/O 2 input opened									
<b>Device Query</b>	<b>SP</b>	<p>"`&lt;',0,0,4,'SP',&lt;number devices present&gt;,&lt;number devices expected&gt; (8 bytes)</p> <p>Sent in response to HE Device Status query.</p> <p><b>Tip:</b> If the number of present and expected devices match, the green Net LED on the HE will blink once per second. If the two numbers do not agree, the LED blinks twice per second.</p>								

# RS-232 Device Response

The following responses are common to all iC-Net 2-Way devices.

Response	Description
<b>New Channel</b>	<p><b>T</b> "`\&lt;,&lt;dh&gt;,&lt;dl&gt;,2,'T',&lt;new channel&gt;" (6 bytes)</p> <p>Sent in response to T? command.</p>
<b>IR Function</b>	<p><b>R</b> "`\&lt;,&lt;dh&gt;,&lt;dl&gt;,2,'F',&lt;IR Function&gt;" (6 bytes)</p> <p>Sent when unit receives a new function command is pressed (1-8) or released (0) from the IR remote.</p> <p>0 = Release            1 = Play            2 = Stop            3 = Pause            4 = Fast Forward            5 = Rewind            8 = Record</p>
<b>IR Key</b>	<p><b>K</b> "`\&lt;,&lt;dh&gt;,&lt;dl&gt;,2,'K',&lt;IR Key&gt;" (6 bytes)</p> <p>Sent when unit receives a new key command is pressed (10-23) or released (0) from the IR remote.</p> <p>0 = Release            10 - 19 = Numeric keypad entry 0 - 9            21 = Enter            22 = Channel Up            23 = Channel Down            29 = Menu            101 = Previous Channel            102 = Timer            105 = Media Menu            106 = Cursor Right            107 = Cursor Left            108 = Cursor Up            109 = Cursor Down            110 = Media Select</p> <p>The 0 - 9, Channel Up/Down functions are sent only if enabled in the TM command (Bit 2 = 1). The Channel Up/Down responses will be sent if the Tune Ring contains no channels - see <b>Ex2</b> in the Tune Ring command section.</p>

Response	Description	
<b>IR Menu</b>	<b>M</b>	<p data-bbox="382 215 1163 248">" ` '&lt;dh&gt;,&lt;dl&gt;,5,'M',&lt;msh&gt;, &lt;msl&gt;, &lt;mph&gt;, &lt;mpl&gt;" (9 bytes)</p> <p data-bbox="382 280 1417 378">Sent when unit receives a new Menu command is pressed or released (0) from the IR remote. Menu Selection high and low bytes are in &lt;msh&gt; and &lt;msl&gt;. Menu Parameter high and low bytes are in &lt;mph&gt; and &lt;mpl&gt;.</p> <p data-bbox="382 410 1425 508">A Menu command is initiated by pressing the Menu key, followed by a numeric entry, then the Enter or Channel Up key. During the Menu process, the Channel Down key acts as a backspace or delete key.</p> <p data-bbox="382 540 1409 605">Some selections that need only a single numeric entry and will have a parameter value of zero (0). Those keys are 0, 8, 9, 18, 20, 30, 900, 911, and 912.</p> <p data-bbox="382 638 1339 670">Menu selections that will prompt the user to enter a second parameter entry are:</p> <ul data-bbox="382 703 617 1011" style="list-style-type: none"> <li>1 = Select Media</li> <li>2 = Password</li> <li>3 = Chapter Search</li> <li>4 = Frame Search</li> <li>11 = Channel</li> <li>21 = Page Zone</li> <li>22 = Page Room</li> <li>25 = Go</li> <li>21 = Attach Zone</li> <li>32 = Attach Room</li> </ul> <p data-bbox="382 1044 1100 1076"><b>Tip:</b> The Menu entries are active even if the TV power is off.</p>

# iC-Net Zones

---

To simplify controlling groups of devices, iC-Net is divided into 16 zones of 255 devices. All the devices within each zone can be controlled simultaneously by sending a command to a single "virtual device number".

For example, noting the zone chart below, if we send a Power On command to device #256, any TV controller numbered between 257 and 511 will instantly turn on. If we send a Power Off command to device #4095, all devices in the system will turn off.

This is an immensely powerful feature, because most systems can only address one device at time. So if you need to turn off all 50 TV in a zone, you would need to send 50 commands. In addition to the hassles of creating multiple commands, there would be a long delay between the first and last command. One command, instant response is easier.

ABC Media Retrieval Systems reserve Zone 0 for devices used in the central control system, 1 -15 for iC-Net devices. This structure may be useful for your application, or you could use Zone 0 just like any other iC-Net zone.

Zone	First Device	Last Device	Virtual Device
0	1	255	0
1	257	511	256
2	513	767	512
3	769	1023	768
4	1025	1279	1024
5	1281	1535	1280
6	1537	1791	1536
7	1793	2047	1792
8	2049	2303	2048
9	2305	2559	2304
10	2561	2815	2560
11	2817	3071	2816
12	3073	3327	3072
13	3329	3583	3328
14	3585	3839	3584
15	3841	4000	3840
All Zones			4095

**Tip:** You've probably figured out that you never want to assign a **virtual device** number to an **actual device** in the system. If you assigned #1536 to a device, all the TV controllers in Zone 6 would respond every time you sent a command to that one device.

# System Map

---

One of the key tasks for iC-Net integrators is to create a logical **System Map**, assigning device numbers to TV controllers so they fall into logical zones. The device mapping could be sorted by type or location; whichever suits the application.

<b>iC-Net Zone</b>	<b>Zone</b>	<b>Room</b>	<b>Device</b>	<b>iC-Net Zone</b>	<b>Zone</b>	<b>Room</b>	<b>Device</b>
1	W 1 <sup>st</sup> Floor		<b>256</b>	5	Coffee Areas		<b>1280</b>
		W151	257			G100	1281
		W152	258			G150	1282
		W153	259			G151	1283
		W154	260	6	Day Care		<b>1536</b>
2	W 2 <sup>nd</sup> Floor		<b>512</b>			TV 1	1537
		W251	513			TV 2	1538
		W252	514	7	Hallways		<b>1792</b>
		W253	515			W1	1793
		W254	516			W2	1794
3	E 1 <sup>st</sup> Floor		<b>768</b>			E1	1795
		E151	769			E2	1796
		E152	770	8	Office		<b>2048</b>
		E153	771			Admin	2049
		E154	772			A/V Center	2050
4	E 2 <sup>nd</sup> Floor		<b>1024</b>	All Zones	All		<b>4095</b>
		E251	1025				
		E252	1024				
		E253	1025				
		E254	1026				

# Typical RF and ICC-Net Signal Flow

This diagram shows the structure of a typical Contemporary Research media retrieval system. One of the key aspects for iCC-Net communication is to provide a forward and return (sub-channel) path for data if you're using 2-way TV Controllers.

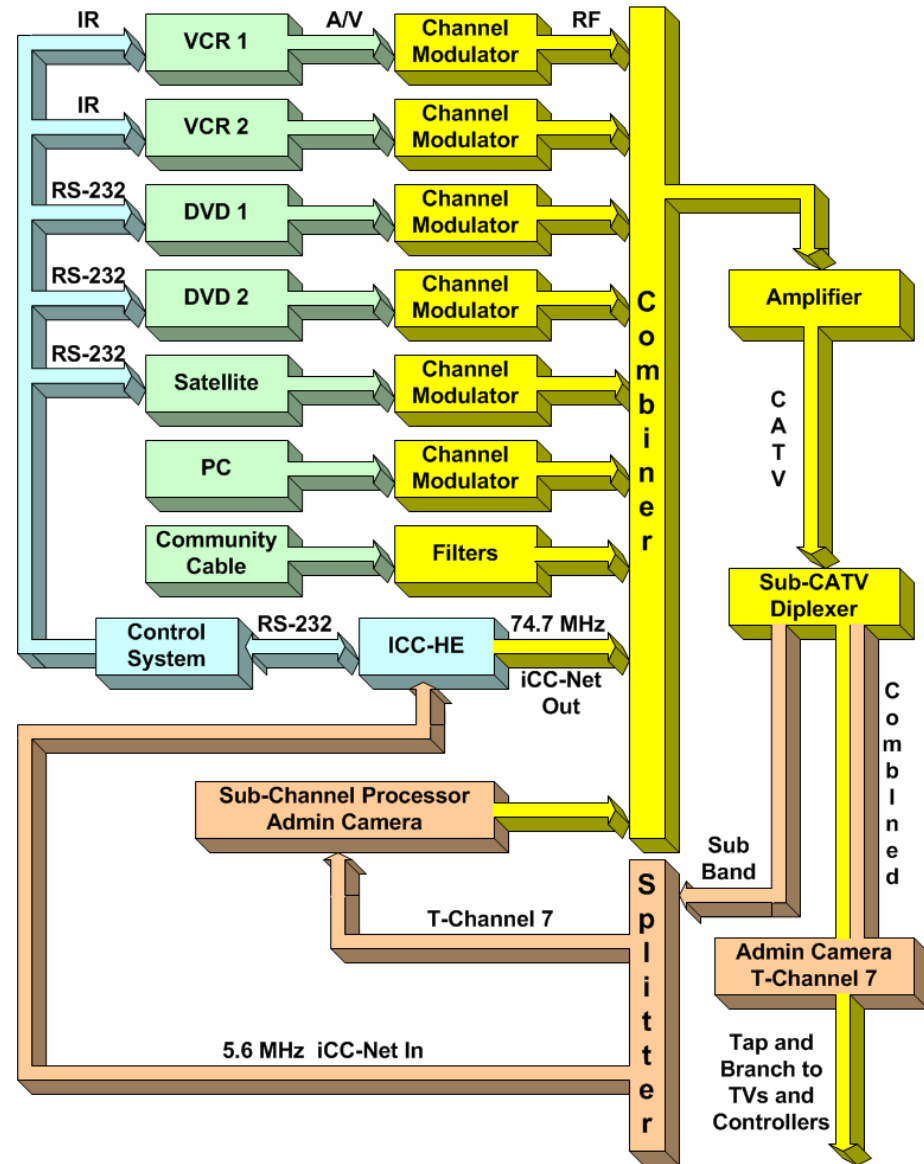

# RF Channel Frequencies

Channel	CATV/IRC	HRC	FCC	Chan	CATV	HRC	FCC	Chan	CATV	HRC	FCC	Chan	CATV	HRC	FCC
<b>T Band</b>					<b>High</b>			47	361.25	360.0180	669.25	79	553.25	552.0276	861.25
<i>iCC-Net</i>	5.6 (In)			7	175.25	174.0087	175.25	48	367.25	366.0183	675.25	80	559.25	558.0279	867.25
T 7	7.00			8	181.25	180.0090	181.25	49	373.25	372.0186	681.25	81	565.25	564.0282	873.25
T 8	13.00			9	187.25	186.0093	187.25	50	379.25	378.0189	687.25	82	571.25	570.0285	879.25
T 9	19.00			10	193.25	192.0096	193.25	51	385.25	384.0192	693.25	83	577.25	576.0288	885.25
T 10	25.00			11	199.25	198.0099	199.25	52	391.25	390.0195	699.25	84	583.25	582.0291	
T 11	31.00			12	205.25	204.0102	205.25	53	397.25	396.0198	705.25	85	589.25	588.0294	
T 12	37.00			13	211.25	210.0105	211.25	54	403.25	402.0201	711.25	86	595.25	594.0297	
T 13	43.00				<b>Super</b>			55	409.25	408.0204	717.25	87	601.25	600.0300	
T14	49.00			23	217.25	216.0108	525.25	56	415.25	414.0207	723.25	88	607.25	606.0303	
<b>Low</b>				24	223.25	222.0111	531.25	57	421.25	420.0210	729.25	89	613.25	612.0306	
2	55.25	54.0027	55.25	25	229.25	228.0114	537.25	58	427.25	426.0213	735.25	90	619.25	618.0309	
3	61.25	60.0030	61.25	26	235.25	234.0117	543.25	59	433.25	432.0216	741.25	91	625.25	624.0312	
4	67.25	66.0033	67.25	27	241.25	240.0120	549.25	60	439.25	438.0219	747.25	92	631.25	630.0315	
<i>iCC-Net</i>	74.7 (Out)*	72.0036*		28	247.25	246.0123	555.25	61	445.25	444.0222	753.25	93	637.25	636.0318	
5	77.25/79.25	78.0039		29	253.25	252.0126	561.25	62	451.25	450.0225	759.25	94	643.25	642.0321	
6	83.25/85.25	84.0042		30	259.25	258.0129	567.25	<b>Hyper</b>				100	649.25	648.0324	
<b>FM</b>				31	265.25	264.0132	573.25	63	457.25	456.0228	765.25	101	655.25	654.0327	
95	91.25	90.0045	91.25	32	271.25	270.0135	579.25	64	463.25	462.0231	771.25	102	661.25	660.0330	
96	97.25	96.0048	97.25	33	277.25	276.0138	585.25	65	469.25	468.0234	777.25	103	667.25	666.0333	
97	103.25	102.0051	103.25	34	283.25	282.0141	591.25	66	475.25	474.0237	783.25	104	673.25	672.0336	
<b>Mid</b>				35	289.25	288.0144	597.25	67	481.25	480.0240	789.25	105	679.25	678.0339	
98	109.25	108.0054	109.25	36	295.25	294.0147	603.25	68	487.25	486.0243	795.25	106	685.25	684.0342	
99	115.25	114.0057	115.25	37	301.25	300.015	609.25	69	493.25	492.0246	801.25	107	691.25	690.0345	
14	121.25	120.0060	471.25	38	307.25	306.0153	615.25	70	499.25	498.0249	807.25	108	697.25	696.0348	
15	127.25	126.0063	477.25	39	313.25	312.0156	621.25	71	505.25	504.0252	813.25	109	703.25	702.0351	
16	133.25	132.0066	483.25	40	319.25	318.0159	627.25	72	511.25	510.0255	819.25	110	709.25	708.0354	
17	139.25	138.0069	489.25	41	325.25	324.0162	633.25	73	517.25	516.0258	825.25	111	715.25	714.0357	
18	145.25	144.0072	495.25	42	331.25	330.0165	639.25	74	523.25	522.0261	831.25	112	721.25	720.0360	
19	151.25	150.0075	501.25	43	337.25	336.0168	645.25	75	529.25	528.0264	837.25	113	727.25	726.0363	
20	157.25	156.0078	507.25	44	343.25	342.0171	651.25	76	535.25	534.0267	843.25	114	733.25	732.0366	
21	163.25	162.0081	513.25	45	349.25	348.0174	657.25	77	541.25	540.0270	849.25	115	739.25	738.0369	
22	169.25	168.0084	519.25	46	355.25	354.0177	663.25	78	547.25	546.0273	855.25	116	745.25	744.0372	

**Frequencies** —The visual carrier frequency (channels T7-116) is shown in this chart, in MHz. For the aural carrier frequency, add 4.5 MHz to the visual carrier. The lower edge of the channel is 1.25 MHz below the visual carrier and the upper edge is 4.75 MHz above the visual carrier.

**CATV/IRC** — IRC spacing is the same as standard CATV frequencies, except for Channels 5 and 6.

**HRC/IRC** — About 10% of CATV systems use these alternate frequency plans, created to reduce "beat" interference.

**FCC** — U.S. Broadcast VHF/UHF

\***Channel 1** — IRC/HRC spacing created a Channel 1 between 4 and 5, the rarely used channel must be shifted to different frequency for IC-Net operation

# iCW-Net Wiring

Use Category 5 or Category 3 wire, 4 pair, unshielded, 24 AWG.

The iCC-HE and iCW-HE Head-End Network Controllers include three iCW-Net ports for twisted-pair wired networking. Control wiring can be home-run to ports or run in a star format, using punch-down blocks or RJ-45 "harmonicas" to distribute signals to multiple iCW-Net devices. Open wiring runs do not need termination.

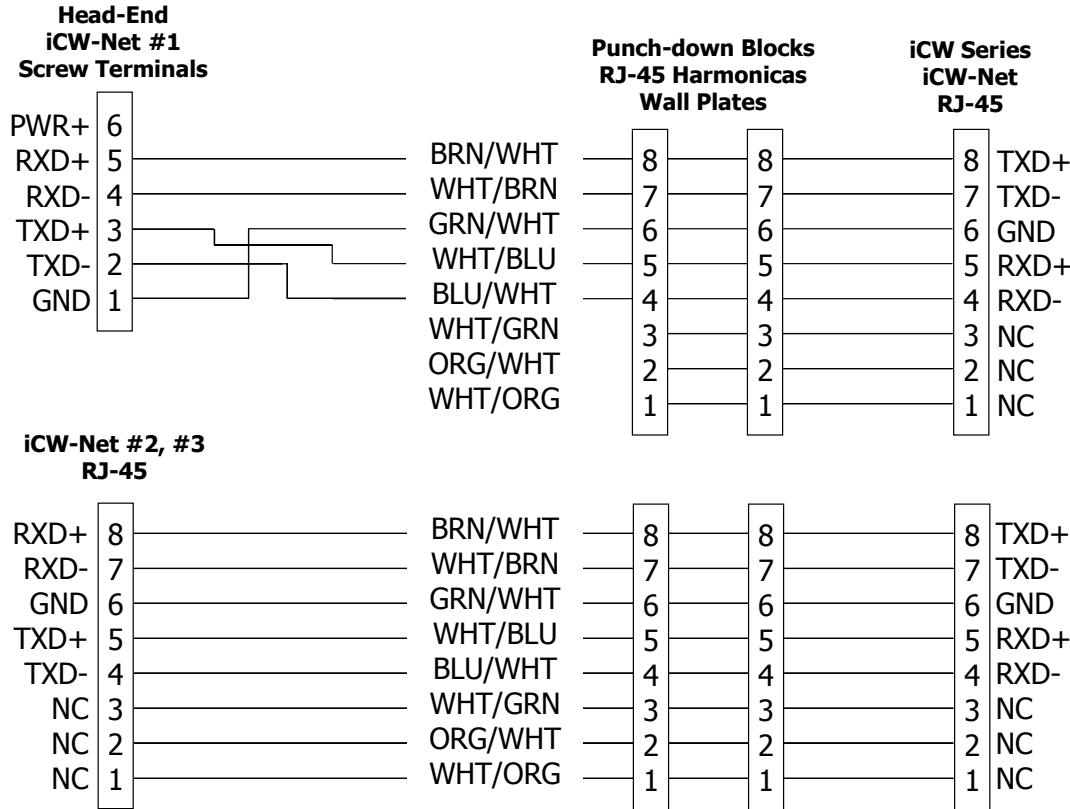

# Safety Instructions

---

Read before operating equipment.

1. **Cleaning** - Unplug this product from the wall outlet before cleaning. Do not use liquid cleaners or aerosol cleaners. Use a damp cloth for cleaning.
2. **Power Sources** - Use supplied or equivalent UL/CSA approved low voltage DC plug-in transformer.
3. **Outdoor Antenna Grounding** - If you connect an outside antenna or cable system to the product, be sure the antenna or cable system is grounded so as to provide some protection against voltage surges and built-up static charges. Section 810 of the National Electrical Code, ANSI/NFPA No. 70, provides information with respect to proper grounding of the mast and supporting structure, grounding of the lead-in wire to an antenna discharge unit, size of grounding conductors, location of antenna discharge unit, connection to grounding electrodes, and requirements for the grounding electrode.
4. **Lightning** - Avoid installation or reconfiguration of wiring during lightning activity.
5. **Power Lines** - Do not locate an outside antenna system near overhead power lines or other electric light or power circuits or where it can fall into such power lines or circuits. When installing an outside antenna system, refrain from touching such power lines or circuits, as contact with them might be fatal.
6. **Overloading** - Do not overload wall outlets and extension cords as this can result in a risk of fire or electric shock.
7. **Object and Liquid Entry** - Never push objects of any kind into this product through openings as they may touch dangerous voltage points or short out parts, resulting in a fire or electric shock. Never spill liquid of any kind on the product.
8. **Servicing** - Do not attempt to service this product yourself as opening or removing covers may expose you to dangerous voltage or other hazards. Refer all servicing to qualified service personnel.
9. **Damage Requiring Service** - Unplug this product from the wall outlet and refer servicing to qualified service personnel under the following conditions:
  - When the power supply cord or plug is damaged.
  - If liquid spills or objects fall into the product.
  - If the product is exposed to rain or water.
  - If the product does not operate normally by following the operating instructions. Adjust only those controls that are covered by the operating instructions. An improper adjustment of other controls may result in damage and will often require extensive work by a qualified technician to restore the product to its normal operation.
  - If the video product is dropped or the cabinet is damaged.
  - When the video product exhibits a distinct change in performance, this indicates a need for service.

Note to CATV system installer: This reminder is provided to call CATV system installer's attention to Article 820-40 of the National Electrical Code (Section 54 of Canadian Electrical Code, Part I), that provides guidelines for proper grounding and, in particular, specifies that the cable ground shall be connected to the grounding system of the building as close to the point of cable entry as possible.

## Limited Warranty and Disclaimer

---

Contemporary Research Corporation (CR) warrants this product to be free from defects in material and workmanship under normal use for a period of two years from the date of purchase from CR. Should such a defect occur CR will repair or replace, at their option, the defective product at no cost for parts or labor.

This warranty extends to product purchased directly from CR or an Authorized CR Dealer. Consumers should inquire from selling dealer as to the nature and extent of the dealer's warranty, if any.

All warranty claims must be shipped pre-paid to the factory. Call or fax to obtain a Return Material Authorization (RMA) number.

CR is not liable for any damages caused by any of its products or for the failure of any products to perform, including any lost profits, lost savings, incidental damages, or consequential damages. CR is not responsible for any claim made by a third party or made for you by a third party. This limitation of liability applies whether damages are sought, or a claim is made, under this warranty or as a tort claim (including negligence and strict product liability), a contract claim, or any other claim. This limitation of liability cannot be waived or amended by any person. This limitation of liability will be effective even if CR or an authorized representative of CR has been advised of the possibility of any such damages.

Some states do not allow a limitation of how long an implied warranty lasts. Some states do not allow the limitation or exclusion of incidental or consequential damages for consumer products. In such states, the limitation or exclusion of the Limited Warranty may not apply to you. This Limited Warranty gives you specific legal rights. You may also have other rights that may vary from state to state. You are advised to consult applicable state laws for a full determination of your rights.

Except as expressly set forth in this Limited Warranty, CR makes no other warranties, expressed or implied, including any implied warranties of merchantability or fitness for a particular purpose. CR expressly disclaims all warranties not stated in this Limited Warranty. Any implied warranties that may be imposed by law are limited to the terms of this Limited Warranty.